

Contents

American National Standards

Call for Comment on Standards Proposals 2
Call for Members (ANS Consensus Bodies) 11
Final Actions 14
Project Initiation Notification System (PINS) 17
ANS Maintained Under Continuous Maintenance 22
ANSI-Accredited Standards Developers Contact Information 23

International Standards

ISO and IEC Draft Standards 24
ISO and IEC Newly Published Standards 27
Registration of Organization Names in the U.S. 30
Proposed Foreign Government Regulations 30
Information Concerning 31

American National Standards

Call for comment on proposals listed

This section solicits public comments on proposed draft new American National Standards, including the national adoption of ISO and IEC standards as American National Standards, and on proposals to revise, reaffirm or withdraw approval of existing American National Standards. A draft standard is listed in this section under the ANSI-accredited standards developer (ASD) that sponsors it and from whom a copy may be obtained. Comments in connection with a draft American National Standard must be submitted in writing to the ASD no later than the last day of the comment period specified herein. Such comments shall be specific to the section(s) of the standard under review and include sufficient detail so as to enable the reader to understand the commenter's position, concerns and suggested alternative language, if appropriate. Please note that the ANSI Executive Standards Council (ExSC) has determined that an ASD has the right to require that interested parties submit public review comments electronically, in accordance with the developer's procedures.

Ordering Instructions for "Call-for-Comment" Listings

1. **Order from the organization indicated for the specific proposal.**
2. **Use the full identification in your order, including the BSR prefix; for example, Electric Fuses BSR/SAE J554.**
3. **Include remittance with all orders.**
4. **BSR proposals will not be available after the deadline of call for comment.**

Comments should be addressed to the organization indicated, with a copy to the Board of Standards Review, American National Standards Institute, 25 West 43rd Street, New York, NY 10036. Fax: 212-840-2298; e-mail: psa@ansi.org

* Standard for consumer products

Comment Deadline: July 15, 2018

ASME (American Society of Mechanical Engineers)

Revision

BSR/ASME B16.14-201x, Ferrous Pipe Plugs, Bushings, and Locknuts with Pipe Threads (revision of ANSI/ASME B16.14-2013)

This Standard covers ferrous pipe plugs, bushings, and locknuts with pipe threads.

[Click here to view these changes in full](#)

Send comments (with copy to psa@ansi.org) to: Jihoon Oh, (212) 591-8544, ohj@asme.org

ASME (American Society of Mechanical Engineers)

Revision

BSR/ASME B16.15-201x, Cast Copper Alloy Threaded Fittings (revision of ANSI/ASME B16.15-2013)

This Standard covers cast Classes 125 and 250 copper-alloy threaded pipe fittings with provisions for substituting wrought copper alloys for plugs, bushings, caps, and couplings in small sizes.

[Click here to view these changes in full](#)

Send comments (with copy to psa@ansi.org) to: Jihoon Oh, (212) 591-8544, ohj@asme.org

ASME (American Society of Mechanical Engineers)

Revision

BSR/ASME B16.22-201x, Wrought Copper and Copper Alloy Solder Joint Pressure Fittings (revision of ANSI/ASME B16.22-2013)

This Standard establishes specifications for wrought copper and wrought copper alloy, solder joint, seamless fittings, designed for use with seamless copper tube conforming to ASTM B88 (water and general plumbing systems), ASTM B280 (air conditioning and refrigeration service), and ASTM B819 (Medical gas systems), as well as fittings intended to be assembled with soldering materials conforming to ASTM B32, brazing materials conforming to AWS A5.8, or with tapered pipe thread conforming to ASME B1.20.1.

[Click here to view these changes in full](#)

Send comments (with copy to psa@ansi.org) to: Jihoon Oh, (212) 591-8544, ohj@asme.org

ASME (American Society of Mechanical Engineers)

Revision

BSR/ASME B16.26-201x, Cast Copper Alloy Fittings for Flared Copper Tubes (revision of ANSI/ASME B16.26-2013)

This Standard establishes specifications for cast copper alloy fittings and nuts used with flared seamless copper tube conforming to ASTM B88 (water and general plumbing systems).

[Click here to view these changes in full](#)

Send comments (with copy to psa@ansi.org) to: Jihoon Oh, (212) 591-8544, ohj@asme.org

NSF (NSF International)

Revision

BSR/NSF 49-201x (i125r2), Biosafety Cabinetry: Design, Construction, Performance, and Field Certification (revision of ANSI/NSF 49-2016)

This Standard applies to Class II (laminar flow) biosafety cabinetry designed to minimize hazards inherent in work with agents assigned to biosafety levels 1, 2, 3, or 4. It also defines the tests that shall be passed by such cabinetry to meet this Standard. This Standard includes basic requirements for the design, construction, and performance of biosafety cabinets that are intended to provide personnel, product, and environmental protection; reliable operation; durability and structural stability; cleanability; limitations on noise level; illumination; vibration; and motor/blower performance.

[Click here to view these changes in full](#)

Send comments (with copy to psa@ansi.org) to: arose@nsf.org

NSF (NSF International)**Revision**

BSR/NSF 53-201x (i109r1), Drinking Water Treatment Units - Health Effects (revision of ANSI/NSF 53-2017)

It is the purpose of this Standard to establish minimum requirements for materials, design and construction, and performance of point-of-use and point-of-entry drinking-water treatment systems that are designed to reduce specific health-related contaminants in public or private water supplies. Such systems include point-of-entry drinking-water treatment systems used to treat all or part of the water at the inlet to a residential facility or a bottled-water production facility, and includes the material and components used in these systems. This Standard also specifies the minimum product literature and labeling information that a manufacturer shall supply to authorized representatives and system owners, as well as the minimum service-related obligations that the manufacturer shall extend to system owners.

[Click here to view these changes in full](#)

Send comments (with copy to psa@ansi.org) to: mleslie@nsf.org

NSF (NSF International)**Revision**

BSR/NSF 350-201x (i32r1), Onsite residential and commercial, water reuse treatment systems (revision of ANSI/NSF 350-2017a)

This Standard contains minimum requirements for onsite residential and commercial graywater treatment systems. Systems may include Graywater reuse treatment systems having a rated treatment capacity up to 5,678 L/d (1,500 gal/d); or Commercial graywater reuse treatment systems. This applies to onsite commercial reuse treatment systems that treat combined commercial facility graywater with capacities exceeding 5,678 L/d (1,500 gal/d) and commercial facility laundry water only of any capacity. Management methods and end uses appropriate for the treated effluent discharged from graywater residential and commercial treatment systems meeting this Standard are limited to subsurface discharge to the environment only.

[Click here to view these changes in full](#)

Send comments (with copy to psa@ansi.org) to: Jason Snider, (734) 418-6660, jsnider@nsf.org

UL (Underwriters Laboratories, Inc.)**Revision**

BSR/UL 73-201x, Standard for Safety for Motor-Operated Appliances (revision of ANSI/UL 73-2012)

This proposal for UL 73 covers: (1) Accessibility of lithium button batteries.

[Click here to view these changes in full](#)

Send comments (with copy to psa@ansi.org) to: Amy Walker, (847) 664-2023, Amy.K.Walker@ul.com

UL (Underwriters Laboratories, Inc.)**Revision**

BSR/UL 588-201x, Standard for Safety for Seasonal and Holiday Decorative Products (revision of ANSI/UL 588-2017)

Proposed revisions to UL 588 cover: (a) parallel-connected lighting strings employing 18 AWG conductors and (b) glass LED lamps used in parallel-connected or series-connected lighting strings.

[Click here to view these changes in full](#)

Send comments (with copy to psa@ansi.org) to: Megan Sepper, (847) 664-3411, Megan.M.Sepper@ul.com

UL (Underwriters Laboratories, Inc.)**Revision**

BSR/UL 817-201x, Standard for Safety for Cord Sets and Power-Supply Cords (revision of ANSI/UL 817-2017)

(1) Addition of requirements for testing of electronic circuitry, new 9.12.1 - 9.12.3 and new section 19A.

[Click here to view these changes in full](#)

Send comments (with copy to psa@ansi.org) to: Linda Phinney, (510) 319-4297, Linda.L.Phinney@ul.com

UL (Underwriters Laboratories, Inc.)**Revision**

BSR/UL 1647-201x, Standard for Safety for Motor-Operated Massage and Exercise Machines (revision of ANSI/UL 1647-2018)

This proposal for UL 1647 covers: (1) Construction requirement revision or clarification for wood or wood composite enclosure materials.

[Click here to view these changes in full](#)

Send comments (with copy to psa@ansi.org) to: Wilbert Fletcher, (919) 549-1337, Wilbert.Fletcher@ul.com

UL (Underwriters Laboratories, Inc.)**Revision**

BSR/UL 2353-201x, Standard for Safety for Single- and Multi-Layer Insulated Winding Wire (revision of ANSI/UL 2353-2016)

This Standard contains requirements for single- and multi-layer insulated winding wire used in transformers without interleaved insulation; and solid insulation and insulated winding wire without interleaved insulation intended for use in accordance with the Standard for Information Technology Equipment - Safety - Part 1: General Requirements, UL 60950-1, the Standard for Medical Electrical Equipment, Part 1: General Requirements for Safety, UL 60601-1, or the Safety of Power Transformers, Power Supplies, Reactors and Similar Products - Part 1: General Requirements and Tests, IEC 61558-1. These requirements are not intended to prohibit use of this type of winding wire in equipment covered by the scope of other standards when these requirements are determined to be compatible with those standards.

[Click here to view these changes in full](#)

Send comments (with copy to psa@ansi.org) to: Megan Monsen, (847) 664-1292, megan.monsen@ul.com

Comment Deadline: July 30, 2018**ACCA (Air Conditioning Contractors of America)****Revision**

BSR/ACCA 4 QM-201X, Maintenance of Residential HVAC Systems (revision of ANSI/ACCA 4 QM-2013)

This standard provides minimum requirements for the inspection, HVAC contractors, of residential HVAC equipment found in one- or two-family dwellings of three or fewer stories. This standard includes checklist tasks for inspecting, testing, and measuring electrical, controls, mechanical, venting, air distribution, and piping systems of residential HVAC systems. The checklists also provide recommended corrective actions which the HVAC contractor shall present to the homeowner to remedy identified faults like cleaning or adjusting, and/or replacing equipment and components on a periodic basis. This standard presumes that the HVAC system was designed, installed, and tested in accordance with original equipment manufacturer's (OEM) instructions, applicable codes, and other industry standards. This standard shall not be used to circumvent safety, health, environmental, or the equipment manufacturer's requirements.

Single copy price: Free online at acca.org/ansi

Obtain an electronic copy from: www.acca.org/ansi

Order from: Danny Halel, (703) 824-8868, danny.halel@acca.org

Send comments (with copy to psa@ansi.org) to: standards-sec@acca.org (Comments on this proposed standard are to be submitted on the "ACCA Public Response Form": available on ACCA.org/ANSI website.)

API (American Petroleum Institute)**Revision**

BSR/API Recommended Practice, 13A, 18th Edition-201x, Drilling Fluids Materials (revision and redesignation of ANSI/API Spec 13A/ISO 13500, 18th Ed-2010)

This Specification covers physical properties and test procedures for materials manufactured for use in oil- and gas-well drilling fluids. The materials covered are barite, hematite, bentonite, non-treated bentonite, attapulgate, sepiolite, technical-grade low-viscosity carboxymethyl cellulose (CMC LVT), technical-grade high-viscosity carboxymethyl cellulose (CMC-HVT), starch, low-viscosity polyanionic cellulose (PAC-LV), high-viscosity polyanionic cellulose (PAC-HV), and drilling-grade Xanthan gum. This Specification is intended for the use of manufacturers of named products.

Single copy price: \$181.00

Obtain an electronic copy from: buflodj@api.org

Send comments (with copy to psa@ansi.org) to: buflodj@api.org

API (American Petroleum Institute)**Revision**

BSR/API Recommended Practice 13B-1, 5th Edition-201x, Field Testing of Water-Based Drilling Fluids (revision and redesignation of ANSI/API RP 13B-1/ISO 10414-1-2008)

This recommended practice provides standard procedures for determining the following characteristics of water-based drilling fluids: (a) drilling fluid density (mud weight); (b) viscosity and gel strength; (c) filtration; (d) water, oil and solids contents; (e) sand content; (f) methylene blue capacity; (g) pH; (h) alkalinity and lime content; (i) chloride content; (j) total hardness as calcium; and (k) low-gravity solids and weighting material concentrations.

Annexes A through L provide additional test methods which may be used for:

- chemical analysis for calcium, magnesium, calcium sulfate, sulfide, carbonate and potassium;
- determination of shear strength;
- determination of resistivity;
- removal of air;
- drill-pipe corrosion monitoring;
- sampling, inspection, and rejection;
- rig-site sampling;
- calibration and verification of glassware, thermometers, timers, viscometers, retort-kit cup and drilling fluid balances;
- permeability-plugging testing at high temperature and high pressure for two types of equipment; and
- SAG testing.

Single copy price: \$165.00

Obtain an electronic copy from: buflodj@api.org

Send comments (with copy to psa@ansi.org) to: buflodj@api.org

API (American Petroleum Institute)**Revision**

BSR/API Recommended Practice 19C, 2nd Edition-201x, Measurement of Proppants Used in Hydraulic Fracturing and Gravel-Packing Operations (revision and redesignation of ANSI/API RP 19C-ISO 13503-2, 1st Edition-2007)

This document provides specifications and standard testing procedures for evaluating proppants used in hydraulic fracturing and gravel-packing operations. The objective of this document is to provide specifications and a consistent methodology for testing performed on hydraulic fracturing and/or gravel-packing proppants. Methodologies and specifications (where applicable) are provided for:

- sieve analysis and median diameter determination;
- sphericity and roundness;
- acid solubility;
- turbidity;
- loose-pack bulk density, apparent density, and absolute density;
- crush resistance; and
- loss on ignition.

Proppant size designation is as per industry standard. It is based on the maximum and minimum size determination by sieve analysis and ASTM 1 sieve number (and not as per standard opening expressed in micrometers). Proppants in this document are sand, ceramic media, resin-coated proppants, gravel-packing media, and other similarly used materials for hydraulic fracturing and gravel-packing operations.

Single copy price: \$113.00

Obtain an electronic copy from: buflodj@api.org

Send comments (with copy to psa@ansi.org) to: buflodj@api.org

ASABE (American Society of Agricultural and Biological Engineers)**New Standard**

BSR/ASABE S644 MONYEAR-201x, Performance Measures of Electromagnetic Radiation Systems for Plants (new standard)

This standard establishes appropriate performance criteria of electromagnetic radiation devices designed for horticultural applications and installed systems that use such devices. This standard requires a minimum set of criteria and recommends optional, advanced criteria. This standard also provides methodologies to compare the anticipated plant response and energy performance between alternative devices and installed systems when applied to diverse horticultural operations.

Single copy price: \$65.00

Obtain an electronic copy from: brace@asabe.org

Order from: Walter Brace, (269) 932-7009, brace@asabe.org

Send comments (with copy to psa@ansi.org) to: Same

ASC X9 (Accredited Standards Committee X9, Incorporated)**Stabilized Maintenance**

BSR X9.100-180-2006 (S201x), Specifications for Electronic Exchange of Check and Image Data (Non-Domestic) (stabilized maintenance of ANSI X9.100-180-2006 (R2013))

This standard, including the normative annexes, establishes the file sequences, record types, and field formats to be used for the electronic exchange of check MICR line data, associated check processing data, check images, and optional user information in the form of cash letters.

Single copy price: \$100.00

Order from: Ambria Frazier, (410) 267-7707, Ambria.frazier@x9.org

Send comments (with copy to psa@ansi.org) to: Same

ASME (American Society of Mechanical Engineers)**New Standard**

BSR/ASME NM-2-201x, Glass-Fiber-Reinforced Thermosetting Resin Piping Systems (new standard)

This Standard provides requirements for the design, materials, manufacture, fabrication, installation, examination, and testing of glass-fiber-reinforced thermosetting-resin piping systems. Glass-fiber-reinforced thermosetting resin piping as used in this Standard includes pipe, flanges, bolting, gaskets, valves, fittings, special connecting components, and the pressure-containing or retaining portions of other piping components, whether manufactured in accordance with documents referenced in this Standard or specially designed. It also includes hangers and supports and other equipment items necessary to prevent overstressing the pressure-containing components.

Single copy price: Free

Obtain an electronic copy from: <http://cstools.asme.org/publicreview>

Order from: Mayra Santiago, ASME; ansibox@asme.org

Send comments (with copy to psa@ansi.org) to: Jihoon Oh, (212) 591-8544, ohj@asme.org

ASME (American Society of Mechanical Engineers)**Revision**

BSR/ASME B16.51-201x, Copper and Copper Alloy Press-Connect Pressure Fittings (revision of ANSI/ASME B16.51-2013)

This Standard establishes requirements for cast copper alloy, wrought copper, and wrought copper alloy, press-connect pressure fittings for use with hard-drawn seamless copper water tube conforming to ASTM B88 for piping systems conveying water.

Single copy price: Free

Obtain an electronic copy from: <http://cstools.asme.org/publicreview>

Order from: Mayra Santiago, ASME; ansibox@asme.org

Send comments (with copy to psa@ansi.org) to: Jihoon Oh, (212) 591-8544, ohj@asme.org

AWS (American Welding Society)**New Standard**

BSR/AWS C4.4/C4M-201X, Recommended Practices for Heat Shaping and Straightening with Oxyfuel Gas Heating Torches (new standard)

The text reviews the theory and analytical calculations that explain how heat shaping and straightening occurs. Sample calculations and tables are presented for typical materials. General heating patterns and heat shaping and straightening techniques are discussed. Specific heating applications are illustrated for various sections.

Single copy price: \$38.00

Obtain an electronic copy from: jrosario@aws.org

Order from: Jennifer Rosario, (800) 443-9353, jrosario@aws.org

Send comments (with copy to psa@ansi.org) to: adavis@aws.org

FM (FM Approvals)**New Standard**

BSR/FM 4930-201x, Evaluating Fire, Wind and Seismic Performance of Cooling Towers (new standard)

This test standard provides a procedure and performance requirements for cooling towers and cooling tower components by evaluating the ability of these products to resist fire, wind and seismic performance requirements.

Single copy price: Free

Obtain an electronic copy from: josephine.mahnken@fmapprovals.com

Order from: Josephine Mahnken, (781) 255-4813, josephine.mahnken@fmapprovals.com

Send comments (with copy to psa@ansi.org) to: josephine.mahnken@fmapprovals.com

HI (Hydraulic Institute)***New Standard***

BSR/HI 14.1-14.2-201x, Rotodynamic Pumps for Nomenclature and Definitions (new standard)

This standard is a normative document for nomenclature and definitions for rotodynamic pump for various pumps configurations and services. This standard is for types, nomenclature, and definitions of rotodynamic pumps with radial, mixed-flow, and axial-flow impellers, as well as regenerative turbine, Pitot tube, vertical diffuser, submersible motor deep-well and short-set pumps, commonly defined as vertically suspended rotor and vertical overhung impeller types (that may be driven by vertical electric motors or horizontal engines with right-angle gears) of all industrial/commercial types.

Single copy price: Free

Obtain an electronic copy from: dgiordano@pumps.org

Order from: Denielle Giordano, (973) 267-9700 EXT 115, dgiordano@pumps.org

Send comments (with copy to psa@ansi.org) to: Same

NECA (National Electrical Contractors Association)***New Standard***

BSR/NECA 417-201X, Recommended Practice for Designing, Installing, Operating, and Maintaining Microgrids (new standard)

This Standard applies to microgrids and provides recommended practices for their design, installation, commissioning, operation, and maintenance.

Single copy price: \$25.00 (NECA members); \$50.00 (non-members)

Obtain an electronic copy from: neis@necanet.org

Order from: Melissa West, (301) 215-4544, melissa.west@necanet.org

Send comments (with copy to psa@ansi.org) to: Same

NSF (NSF International)***New Standard***

BSR/NSF 455-3-201x (i1r1), Good Manufacturing Practices for Cosmetics (new standard)

This Standard is intended to define a standardized approach for auditing to determine the level of compliance of cosmetic products to ISO 22716 Good Manufacturing Practices (GMPs) for cosmetics as well as incorporating additional retailer requirements. It refers to the requirements for GMPs applicable to all cosmetics. It will assist in the determination of adequate facilities and controls for cosmetic manufacture with sufficient quality to ensure suitability for intended use.

Single copy price: Free

Obtain an electronic copy from: https://standards.nsf.org/apps/group_public/download.php/42987/455-3i1r1%20-%20Good%20Manufacturing%20Practices%20for%20Cosmetics%20-%20JC%20memo%20&%20ballot.pdf

Send comments (with copy to psa@ansi.org) to: rbrooker@nsf.org

NSF (NSF International)***New Standard***

BSR/NSF 455-4-201x (i1r1), Good Manufacturing Practices for Over-the-Counter Drugs (new standard)

This Standard is intended to define a standardized approach for auditing to determine the level of compliance of over-the-counter (OTC) drug products to 21 CFR 210 and 211 Good Manufacturing Practices (GMPs) in the manufacturing, processing, packing, or holding of drugs for finished pharmaceuticals as well as incorporating additional retailer requirements. It refers to the requirements for GMPs applicable to all OTC drugs. It will assist in the determination of adequate facilities and controls for OTC drug manufacture with sufficient quality to ensure suitability for intended use.

Single copy price: Free

Obtain an electronic copy from: https://standards.nsf.org/apps/group_public/download.php/43021/455-4%20-%20Good%20Manufacturing%20Practices%20for%20Over-the-Counter%20Drugs%20-%20JC%20memo%20&%20ballot.pdf

Send comments (with copy to psa@ansi.org) to: rbrooker@nsf.org

SCTE (Society of Cable Telecommunications Engineers)***Revision***

BSR/SCTE 62-201x, Measurement Procedure for Noise Figure (revision of ANSI/SCTE 62-2012)

This procedure defines a method of measurement for the noise figure of active cable telecommunications equipment. It is intended for measurement of 75-ohm devices having type "F" or 5/8-24 KS connectors, and for the measurement of true broadband noise as opposed to narrowband disturbances.

Single copy price: \$50.00

Obtain an electronic copy from: Global Engineering Documents, www.global.ihs.com

Order from: Kim Cooney, (800) 542-5040, kcooney@scte.org

Send comments (with copy to psa@ansi.org) to: Same

SCTE (Society of Cable Telecommunications Engineers)**Revision**

BSR/SCTE 116-201x, Specification for 5/8-24 Port, Female Adapters (revision of ANSI/SCTE 116-2011)

The purpose of this specification is to serve as a recommended guideline for the physical dimensions of female 5/8 - 24 port that is used on hard-line adapters for interconnection in the 75-ohm RF broadband communications industry.

Single copy price: \$50.00

Obtain an electronic copy from: Global Engineering Documents, www.global.ihs.com

Order from: Kim Cooney, (800) 542-5040, kcooney@scte.org

Send comments (with copy to psa@ansi.org) to: Same

SCTE (Society of Cable Telecommunications Engineers)**Revision**

BSR/SCTE 119-201x, Measurement Procedure for Noise Power Ratio (revision of ANSI/SCTE 119-2011)

This procedure defines a method of measurement for Noise Power Ratio (NPR) of active cable telecommunications equipment. It is intended for measurement of 75-ohm devices having type "F" or 5/8-24 KS connectors.

Single copy price: \$50.00

Obtain an electronic copy from: Global Engineering Documents, www.global.ihs.com

Send comments (with copy to psa@ansi.org) to: admin@standards.scte.org

UL (Underwriters Laboratories, Inc.)**New Standard**

BSR/UL 1699B-201X, Standard for Safety for Photovoltaic (PV) DC Arc-Fault Circuit Protection (new standard)

These requirements cover DC photovoltaic arc-fault circuit protection devices intended for use in solar photovoltaic electrical energy systems as described in Article 690 of the National Electrical Code, NFPA 70. This protection is intended to mitigate the effects of arcing faults that may pose a risk of fire ignition under certain conditions if the arcing persists.

Single copy price: Free

Obtain an electronic copy from: <http://www.shopulstandards.com>

Send comments (with copy to psa@ansi.org) to: Patricia Sena, (919) 549-1636, patricia.a.sena@ul.com

UL (Underwriters Laboratories, Inc.)**Revision**

BSR/UL 852-201x, Standard for Safety for Metallic Sprinkler Pipe for Fire Protection Service (revision of ANSI/UL 852-2010 (R2014))

This proposal for UL 852 covers: (1) Fire test revision.

Single copy price: Free

Obtain an electronic copy from: <http://www.shopulstandards.com>

Send comments (with copy to psa@ansi.org) to: Griff Edwards, (919) 549-0956, griff.edwards@ul.com

UL (Underwriters Laboratories, Inc.)**Revision**

BSR/UL 1008-201X, Standard for Safety for Transfer Switch Equipment (revision of ANSI/UL 1008-2015)

(2) Revisions to address the grounding and bonding of neutral circuits; (3) Revision to the overload, endurance, and short circuit testing; (4) Miscellaneous revisions regarding inlet assemblies, mechanical interlocking of single-pole inlets and readily accessible service disconnect switches; (7) Revisions to Annex E to cover freestanding complete packaged fire pump power transfer units; (8) Revisions to address system available fault calculations for momentary paralleling situations; and (10) Revised requirements for monitoring the temperature on inlets.

Single copy price: Free

Obtain an electronic copy from: <http://www.shopulstandards.com>

Send comments (with copy to psa@ansi.org) to: Patricia Sena, (919) 549-1636, patricia.a.sena@ul.com

Comment Deadline: August 14, 2018

Reaffirmations and withdrawals available electronically may be accessed at: webstore.ansi.org

ASME (American Society of Mechanical Engineers)

Reaffirmation

BSR/ASME Y14.34-2013 (R201x), Associated Lists (reaffirmation of ANSI/ASME Y14.34-2013)

This Standard establishes the minimum requirements for the preparation and revision of application lists, data lists, index lists, parts lists, and wire lists. In addition, this Standard presents certain options that may be incorporated into application lists, data lists, index lists, parts lists, and wire lists at the discretion of the design activity.

Single copy price: \$45.00

Obtain an electronic copy from: <http://cstools.asme.org/publicreview>

For Reaffirmations and Withdrawn standards, please view our catalog at <https://www.asme.org/shop/standards>.

Send comments (with copy to psa@ansi.org) to: Fredric Constantino, (212) 591-8684, constantinof@asme.org

ASME (American Society of Mechanical Engineers)

Stabilized Maintenance

BSR/ASME Y32.18-1972 (S201x), Symbols for Mechanical and Acoustical Elements as Used in Schematic Diagrams (stabilized maintenance of ANSI/ASME Y32.18-1972 (R2013))

This document presents standard symbols and definitions that may be used in constructing schematic diagrams for mechanical and acoustical systems whose performances are described by finite sets of scalar variables.

Single copy price: \$33.00

Obtain an electronic copy from: <http://cstools.asme.org/publicreview>

Order from: Mayra Santiago, ASME; ansibox@asme.org

Send comments (with copy to psa@ansi.org) to: Fredric Constantino, (212) 591-8684, constantinof@asme.org

UL (Underwriters Laboratories, Inc.)

New National Adoption

BSR/UL 15027-2-201X, Standard for Immersion Suits - Part 2: Abandonment suits, requirements including safety (national adoption with modifications of ISO 15027-2)

UL proposes the adoption of the first edition of the Standard for Immersion Suits - Part 2: Abandonment Suits, Requirements Including Safety, UL 15027-2.

Single copy price: Free

Obtain an electronic copy from: <https://csds.ul.com/Home/ProposalsDefault.aspx>

Send comments (with copy to psa@ansi.org) to: Nicolette Weeks, (919) 549-0973, Nicolette.A.Weeks@ul.com

UL (Underwriters Laboratories, Inc.)

New National Adoption

BSR/UL 15027-3-201X, Standard for Immersion suits - Part 3: Test methods (national adoption with modifications of ISO 15027-3)

UL proposes the adoption of the first edition of the Standard for Immersion Suits - Part 3: Test Methods, UL 15027-3.

Single copy price: Free

Obtain an electronic copy from: <https://csds.ul.com/Home/ProposalsDefault.aspx>

Send comments (with copy to psa@ansi.org) to: Nicolette Weeks, (919) 549-0973, Nicolette.A.Weeks@ul.com

UL (Underwriters Laboratories, Inc.)

New National Adoption

BSR/UL 60079-0-201X, Standard for Safety for Explosive Atmospheres - Part 0: General Requirements (national adoption of IEC 60079-0 with modifications and revision of ANSI/UL 60079-0-2013 (R2017))

Adoption of IEC 60079-0, Explosive Atmospheres - Part 0: General Requirements, (seventh edition issued by IEC December 2017) as a new UL IEC-based UL standard, UL 60079-0 with US Differences.

Single copy price: Free

Obtain an electronic copy from: <https://csds.ul.com/Home/ProposalsDefault.aspx>

Send comments (with copy to psa@ansi.org) to: Vickie Hinton, (919) 549-1851, Vickie.T.Hinton@ul.com

UL (Underwriters Laboratories, Inc.)**Revision**

BSR/UL 217-201x, Standard for Safety for Smoke Alarms (revision of ANSI/UL 217-2016)

Proposed 9th edition of UL 217 is a binational standard merging requirements from ULC-S531 and UL 217 into one standard serving both Canada and the United States. Minor, negligible differences in requirements have been eliminated through harmonization.

Single copy price: Free

Obtain an electronic copy from: <https://csds.ul.com/Home/ProposalsDefault.aspx>

Send comments (with copy to psa@ansi.org) to: Paul Lloret, (510) 319-4269, Paul.E.Lloret@ul.com

Projects Withdrawn from Consideration

An accredited standards developer may abandon the processing of a proposed new or revised American National Standard or portion thereof if it has followed its accredited procedures. The following projects have been withdrawn accordingly:

API (American Petroleum Institute)

BSR/API MPMS Ch. 22.4, 1st Edition-200x, Testing Protocol for Pressure, Differential Pressure, and Temperature Measuring Devices (new standard)

API (American Petroleum Institute)

BSR/API MPMS Ch. 22.5, 1st Edition-200x, Testing Protocol for Electronic Flow Computer Calculations (new standard)

API (American Petroleum Institute)

BSR/MPMS Ch. 2.2D/ISO 7507-4, 2nd edition-200x, Calibration of Upright Cylindrical Tanks Using the Internal Electro-optical Distance Ranging Method (identical national adoption of ISO 7507-4)

Inquiries may be directed to Stephen Crimardo, (202) 682-8151, crimardos@api.org

IWCA (ASC I14) (International Window Cleaning Association)

BSR/IWCA I-14-201x, Window Cleaning Safety (new standard)

IWCA (ASC I14) (International Window Cleaning Association)

BSR/IWCA I-14.1-201x, Window Cleaning Safety (new standard)

MHI (ASC MHC) (Material Handling Industry)

BSR MH10.8.1-201X, Packaging - Bar code and two-dimensional symbols for shipping, transport and receiving labels (identical national adoption of ISO 15394:2017)

MHI (ASC MHC) (Material Handling Industry)

BSR MH10.8.7-201X, Packaging - Labelling and direct product marking with linear bar code and two-dimensional symbols (identical national adoption of ISO 28219:2017)

Call for Members (ANS Consensus Bodies)

Directly and materially affected parties who are interested in participating as a member of an ANS consensus body for the standards listed below are requested to contact the sponsoring standards developer directly and in a timely manner.

ASME (American Society of Mechanical Engineers)

Office: Two Park Avenue
New York, NY 10016-5990

Contact: *Mayra Santiago*

Phone: (212) 591-8521

Fax: (212) 591-8501

E-mail: ansibox@asme.org

BSR/ASME B40.100-2013, Pressure Gauges and Gauge Attachments
(revision of ANSI/ASME B40.100-2013)

BSR/ASME B40.200-200x, Thermometers, Direct Reading and Remote
Reading (revision of ANSI/ASME B40.200-2008 (R2013))

ASSP (ASC A10) (American Society of Safety Professionals)

Office: 520 N. Northwest Hwy.
Park Ridge, IL 60068

Contact: *Lauren Bauerschmidt*

Phone: (847) 768-3475

E-mail: LBauerschmidt@assp.org

BSR/ASSP A10.18-201x, Safety Requirements for Temporary Roof and
Floor Holes, Wall Openings, Stairways, and Other Unprotected Edges
in Construction and Demolition Operations (revision and
redesignation of ANSI/ASSE A10.18-2007 (R2012))

BSR/ASSP A10.23-201x, Safety Requirements for the Installation of
Drilled Shafts (revision and redesignation of ANSI/ASSE A10.23
-2014)

CRRC (Cool Roof Rating Council)

Office: 2435 N Lombard Street
Portland, OR 97217

Contact: *Sarah Schneider*

Phone: (503) 606-8448 EXT 502

E-mail: sarah@coolroofs.org

BSR/CRRC S100-201x, Standard Test Methods for Determining
Radiative Properties of Materials (revision of ANSI/CRRC S100-2016)

HI (Hydraulic Institute)

Office: 6 Campus Drive
Parsippany, NJ 07054

Contact: *Denielle Giordano*

Phone: (973) 267-9700 EXT 115

E-mail: dgiordano@pumps.org

BSR/HI 14.1-14.2-201x, Rotodynamic Pumps for Nomenclature and
Definitions (new standard)

NECA (National Electrical Contractors Association)

Office: 3 Bethesda Metro Center
Suite 1100
Bethesda, MD 20814

Contact: *Melissa West*

Phone: (301) 215-4544

E-mail: melissa.west@necanet.org

BSR/NECA 417-201X, Recommended Practice for Designing, Installing,
Operating, and Maintaining Microgrids (new standard)

NSF (NSF International)

Office: 789 N. Dixboro Road
Ann Arbor, MI 48105-9723

Contact: *Allan Rose*

Phone: (734) 827-3817

Fax: (734) 827-7875

E-mail: arose@nsf.org

BSR/NSF 49-201x (i125r2), Biosafety Cabinetry: Design, Construction,
Performance, and Field Certification (revision of ANSI/NSF 49-2016)

BSR/NSF 53-201x (i109r1), Drinking Water Treatment Units - Health
Effects (revision of ANSI/NSF 53-2017)

BSR/NSF 350-201x (i32r1), Onsite residential and commercial, water
reuse treatment systems (revision of ANSI/NSF 350-2017a)

BSR/NSF 455-3-201x (i1r1), Good Manufacturing Practices for
Cosmetics (new standard)

NSF International Designations

In the September 5, 2014 Standards Action, NSF International
announced a new family of standards for a program called the Global
Retailers and Manufacturers Alliance (GRMA). Since then, BSR/NSF
455-3-201x has been withdrawn from consideration and the
designation and title of these PINS have been reassigned. The re-
designation of these proposed ANS are as follows:

BSR/NSF 455-1-201x, Glossary of GRMA terminology (PINS to be
filed shortly)

BSR/NSF 455-2-201x, Good Manufacturing Practices for Dietary
Supplements

BSR/NSF 455-3-201x, Good Manufacturing Practices for Cosmetics

BSR/NSF 455-4-201x, Good Manufacturing Practices for Over the
Counter Drugs

BSR/NSF 455-4-201x (i1r1), Good Manufacturing Practices for Over-the-Counter Drugs (new standard)

NSF International Designations

In the September 5, 2014 Standards Action, NSF International announced a new family of standards for a program called the Global Retailers and Manufacturers Alliance (GRMA). Since then, BSR/NSF 455-3-201x has been withdrawn from consideration and the designation and title of these PINS have been reassigned. The re-designation of these proposed ANS are as follows:

BSR/NSF 455-1-201x, Glossary of GRMA terminology (PINS to be filed shortly)

BSR/NSF 455-2-201x, Good Manufacturing Practices for Dietary Supplements

BSR/NSF 455-3-201x, Good Manufacturing Practices for Cosmetics

BSR/NSF 455-4-201x, Good Manufacturing Practices for Over the Counter Drugs

PDA (Parenteral Drug Association)

Office: Bethesda Towers, 4350 East-West Highway
Bethesda, MD 20814

Contact: *Christine Alston-Roberts*

Phone: (301)-656-5900-ext.106

E-mail: roberts@pda.org

BSR/PDA Standard 01-201x, Enhanced Purchasing Controls to Support the Bio-Pharmaceutical, Pharmaceutical, Medical Devices and Combination Products Industries (new standard)

BSR/PDA Standard 02-201x, Cryopreservation of Cells for Use in Cell Therapies and Regenerative Medicine Manufacturing (new standard)

VITA (VMEbus International Trade Association (VITA))

Office: 929 W. Portobello Avenue
Mesa, AZ 85210

Contact: *Jing Kwok*

Phone: (602) 281-4497

E-mail: jing.kwok@vita.com

BSR/VITA 66.1-201xx, Optical Interconnect on VPX - MT Variant (revision of ANSI/VITA 66.1-2012)

BSR/VITA 67.0-201xx, Coaxial Interconnect on VPX - Base Standard (revision of ANSI/VITA 67.0-2012)

Call for Members (ANS Consensus Bodies)

Call for Committee Members

ASC O1 – Safety Requirements for Woodworking Machinery

Are you interested in contributing to the development and maintenance of valuable industry safety standards? The ASC O1 is currently looking for members in the following categories:

- General Interest
- Government
- Producer
- User

If you are interested in joining the ASC O1, contact WMMA Associate Director Jennifer Miller at jennifer@wmma.org.

Final Actions on American National Standards

The standards actions listed below have been approved by the ANSI Board of Standards Review (BSR) or by an ANSI-Audited Designator, as applicable.

APCO (Association of Public-Safety Communications Officials-International)

Revision

ANSI/APCO 3.108.2-2018, Core Competencies and Minimum Training Standards for Public Safety Communications Instructor (revision and redesignation of ANSI/APCO 3.108.1-2014): 6/7/2018

ASABE (American Society of Agricultural and Biological Engineers)

Revision

ANSI/ASABE S613-3.1-JUN2018, Tractors and self-propelled machinery for agriculture - Air quality systems for cabs - Part 3: Filters for environmental cab HVAC systems (revision and redesignation of ANSI/ASABE S613-3-JUN2013): 6/8/2018

ASHRAE (American Society of Heating, Refrigerating and Air-Conditioning Engineers, Inc.)

Addenda

- * ANSI/ASHRAE 135.1p-2018, Method of Test for Conformance to BACnet (addenda to ANSI/ASHRAE Standard 135.1-2013): 6/1/2018
- * ANSI/ASHRAE 135.1r-2018, Method of Test for Conformance to BACnet (addenda to ANSI/ASHRAE Standard 135.1-2013): 6/1/2018

New Standard

ANSI/ASHRAE Standard 41.2-2018, Standard Methods for Air Velocity and Airflow Measurement (new standard): 6/1/2018

ANSI/ASHRAE Standard 215-2018, Method of Test to Determine Leakage of Operating HVAC Air Distribution Systems (new standard): 6/1/2018

Revision

ANSI/ASHRAE Standard 128-2018, Method of Rating Portable Air Conditioners (revision of ANSI/ASHRAE Standard 128-2011): 6/1/2018

ASME (American Society of Mechanical Engineers)

Revision

ANSI/ASME B30.25-2018, Scrap and Material Handlers (revision of ANSI/ASME B30.25-2013): 6/8/2018

ASTM (ASTM International)

New Standard

ANSI/ASTM E585-2018, Specification for Compacted Mineral-Insulated, Metal-Sheathed, Base Metal Thermocouple Cable (new standard): 6/1/2018

Reaffirmation

ANSI/ASTM E1799-2018 (R2018), Practice for Visual Inspections of Photovoltaic Modules (reaffirmation of ANSI/ASTM E1799-2018): 5/22/2018

ANSI/ASTM E1802-2018 (R2018), Test Methods for Wet Insulation Integrity Testing of Photovoltaic Modules (reaffirmation of ANSI/ASTM E1802-2018): 5/22/2018

ANSI/ASTM E2481-2018 (R2018), Test Method for Hot Spot Protection Testing of Photovoltaic Modules (reaffirmation of ANSI/ASTM E2481-2018): 5/22/2018

ANSI/ASTM E2848-2018 (R2018), Test Method for Reporting Photovoltaic Non-Concentrator System Performance (reaffirmation of ANSI/ASTM E2848-2018): 5/22/2018

ANSI/ASTM E2908-2018 (R2018), Guide for Fire Prevention for Photovoltaic Panels, Modules, and Systems (reaffirmation of ANSI/ASTM E2908-2018): 5/22/2018

ANSI/ASTM E2939-2018 (R2018), Practice for Determining Reporting Conditions and Expected Capacity for Photovoltaic Non-Concentrator Systems (reaffirmation of ANSI/ASTM E2939-2018): 5/22/2018

ANSI/ASTM F2798-2009 (R2018), Specification for Sealless Lube Oil Pump with Oil Through Motor for Marine Applications (reaffirmation of ANSI/ASTM F2798-2009 (R2014)): 5/22/2018

ANSI/ASTM F2826-2014 (R2018), Test Method for Evaluating the Sustained Air Performance and Exhaust Emission Efficiencies of Central Vacuum Cleaning Units (reaffirmation of ANSI/ASTM F2826-2014): 5/22/2018

Revision

ANSI/ASTM D7547-2018, Specification for Hydrocarbon Unleaded Aviation Gasoline (revision of ANSI/ASTM D7547-2017): 5/22/2018

ANSI/ASTM D7826-2018, Guide for Evaluation of New Aviation Gasolines and New Aviation Gasoline Additives (revision of ANSI/ASTM D7826-2017): 5/22/2018

ANSI/ASTM E23-2018, Test Methods for Notched Bar Impact Testing of Metallic Materials (revision of ANSI/ASTM E23-2016): 6/1/2018

ANSI/ASTM E119-2018, Test Methods for Fire Tests of Building Construction and Materials (revision of ANSI/ASTM E119-2016): 6/1/2018

ANSI/ASTM E1350-2018, Guide for Testing Sheathed Thermocouples, Thermocouples Assemblies, and Connecting Wires Prior to, and After Installation or Service (revision of ANSI/ASTM E1350-2017): 5/22/2018

ANSI/ASTM E2816-2018b, Test Methods for Fire Resistive Metallic HVAC Duct Systems (revision of ANSI/ASTM E2816-2018): 6/1/2018

ANSI/ASTM F608-2018, Test Method for Evaluation of Carpet Embedded Dirt Removal Effectiveness of Household/Commercial Vacuum Cleaners (revision of ANSI/ASTM F608-2017): 5/22/2018

ANSI/ASTM F721-2018, Specification for Gage Piping Assemblies (revision of ANSI/ASTM F721-81 (R2014)): 5/22/2018

ANSI/ASTM F858-2018, Specification for Hot Water Sanitizing Commercial Dishwashing Machines, Single Tank, Conveyor Rack Type (revision of ANSI/ASTM F858-2007 (R2013)): 5/22/2018

ANSI/ASTM F1007-2018, Specification for Pipeline Expansion Joints of the Packed Slip Type for Marine Application (revision of ANSI/ASTM F1007-1997 (R2014)): 5/22/2018

CSA (CSA Group)

New National Adoption

- * ANSI/CSA LNG 3.1-2018, Road Vehicles - Liquefied natural gas (LNG) fuel system components - Part 1: General requirements and definitions (national adoption with modifications of ISO 12614-1): 6/8/2018

- * ANSI/CSA LNG 3.2-2018, Road vehicles - Liquefied natural gas (LNG) fuel system components - Part 2: Performance and general test methods (national adoption with modifications of ISO 12614-2): 6/8/2018
- * ANSI/CSA LNG 3.3-2018, Road vehicles - Liquefied natural gas (LNG) fuel system components - Part 3: Check valve (national adoption with modifications of ISO 12614-3): 6/8/2018
- * ANSI/CSA LNG 3.4-2018, Road vehicles - Liquefied natural gas (LNG) fuel system components - Part 4: Manual valve (national adoption with modifications of ISO 12614-4): 6/8/2018
- * ANSI/CSA LNG 3.5-2018, Road vehicles - Liquefied natural gas (LNG) fuel system components - Part 5: Tank pressure gauge (national adoption with modifications of ISO 12614-5): 6/8/2018
- * ANSI/CSA LNG 3.7-2018, Road vehicles - Liquefied natural gas (LNG) fuel system components - Part 7: Pressure relief valve (national adoption with modifications of ISO 12614-7): 6/8/2018
- * ANSI/CSA LNG 3.8-2018, Road vehicles - Liquefied natural gas (LNG) fuel system components - Part 8: Excess flow valve (national adoption with modifications of ISO 12614-8): 6/8/2018
- * ANSI/CSA LNG 3.9-2018, Road vehicles - Liquefied natural gas (LNG) fuel system components - Part 9: Gas-tight housing and ventilation hose (national adoption with modifications of ISO 12614-9): 6/8/2018
- * ANSI/CSA LNG 3.10-2018, Road vehicles - Liquefied natural gas (LNG) fuel system components - Part 10: Rigid fuel line in stainless steel (national adoption with modifications of ISO 12614-10): 6/8/2018
- * ANSI/CSA LNG 3.11-2018, Road vehicles - Liquefied natural gas (LNG) fuel system components - Part 11: Fittings (national adoption with modifications of ISO 12614-11): 6/8/2018
- * ANSI/CSA LNG 3.12-2018, Road vehicles - Liquefied natural gas (LNG) fuel system components - Part 12: Rigid fuel line in copper and its alloys (national adoption with modifications of ISO 12614-12): 6/8/2018
- * ANSI/CSA LNG 3.13-2018, Road vehicles - Liquefied natural gas (LNG) fuel system components - Part 13: Tank pressure control regulator (national adoption with modifications of ISO 12614-13): 6/8/2018
- * ANSI/CSA LNG 3.14-2018, Road vehicles - Liquefied natural gas (LNG) fuel system components - Part 14: Differential pressure fuel content gauge (national adoption with modifications of ISO 12614-14): 6/8/2018
- * ANSI/CSA LNG 3.15-2018, Road vehicles - Liquefied natural gas (LNG) fuel system components - Part 15: Capacitance fuel content gauge (national adoption with modifications of ISO 12614-15): 6/8/2018
- * ANSI/CSA LNG 3.16-2018, Road vehicles - Liquefied natural gas (LNG) fuel system components - Part 16: Heat exchanger-vaporizer (national adoption with modifications of ISO 12614-16): 6/8/2018
- * ANSI/CSA LNG 3.18-2018, Road vehicles - Liquefied natural gas (LNG) fuel system components - Part 18: Gas temperature sensor (national adoption with modifications of ISO 12614-18): 6/8/2018
- * ANSI/CSA LNG 3.19-2018, Road vehicles - Liquefied natural gas (LNG) fuel system components - Part 19: Automatic valve (national adoption with modifications of ISO 12614-19): 6/8/2018

New Standard

ANSI/CSA LNG 4.1-2018, Liquefied natural gas (LNG) dispensing systems for natural gas vehicles (NGV) (new standard): 6/8/2018

MHI (Material Handling Industry)

Revision

ANSI/MHI ICWM-2018, Vocabulary, Performance and Testing Requirements for Casters and Wheels (revision of ANSI/MHI ICWM-2012): 6/11/2018

NEMA (ASC C136) (National Electrical Manufacturers Association)

Revision

ANSI C136.31-2018, Standard for Roadway and Area Lighting Equipment - Luminaire Vibration (revision of ANSI C136.31-2010): 6/5/2018

NEMA (ASC C78) (National Electrical Manufacturers Association)

Stabilized Maintenance

- ANSI C78.LL4-2003 (S2018), Standard for Electric Lamps - Procedures for Incandescent Lamps - Sample Preparation and the Toxicity Characteristic Leaching Procedure (stabilized maintenance of ANSI C78.LL4-2003 (R2011)): 6/8/2018
- * ANSI C78.30-1997 (S2018), Standard for Electric Lamps - Procedure for Use in Preparation of Lamp Space Drawings (stabilized maintenance of ANSI C78.30-1997 (R2011)): 6/8/2018
- ANSI C78.389-1989 (S2018), Standard for Electric Lamps - High Intensity Discharge - Methods of Measuring Characteristics (stabilized maintenance of ANSI C78.389-1989 (R2009)): 6/8/2018
- * ANSI C78.1432-1997 (S2018), Standard for Electric Lamps - Tungsten-Halogen Lamps with GZ9.5 Two-Pin, Prefocus Bases and 36.5mm Nominal Light Center Length (stabilized maintenance of ANSI C78.1432-1997 (R2011)): 6/8/2018
- * ANSI C78.1433-2001 (S2018), Standard for Electric Lamps - Two-inch (51mm) Dichroic Coated Integral Reflector, Rim Reference, Tungsten Halogen Large Screen Projection Lamps with GX5.3 Bases (stabilized maintenance of ANSI C78.1433-2001 (R2011)): 6/8/2018
- * ANSI C78.1434-2001 (S2018), Standard for Electric Lamps - Condensing Dichroic Coated Integral Reflector Side Pin Tungsten Halogen Projection Lamps with GX7.9 Bases (stabilized maintenance of ANSI C78.1434-2001 (R2011)): 6/8/2018
- * ANSI C78.1435-2002 (S2018), Standard for Electric Lamps - Projection Lamps - Tungsten-Halogen Lamps with G5.3 Bases (stabilized maintenance of ANSI C78.1435-2002 (R2011)): 6/8/2018
- ANSI C78.1451-2002 (S2018), Standard for Electric Lamps - Use of Protective Shields with Tungsten-Halogen Lamps - Cautionary Notice (stabilized maintenance of ANSI C78.1451-2002 (R2011)): 6/8/2018
- * ANSI C78.60432.2-2004 (S2018), Standard for Electric Lamps - Incandescent Lamps - Safety Specifications - Part 2: Tungsten Halogen Lamps for Domestic and Similar General Lighting Purposes (stabilized maintenance of ANSI C78.60432.2-2004 (R2011)): 6/8/2018
- * ANSI C78.60432.3-2007 (S2018), Standard for Electric Lamps - Incandescent Lamps - Safety Specifications - Part 3: Tungsten-Halogen Lamps (Non-Vehicle) (stabilized maintenance of ANSI C78.60432.3-2007 (R2011)): 6/8/2018

NEMA (ASC C8) (National Electrical Manufacturers Association)

Revision

ANSI ICEA T-34-664-2018, Test Method for Conducting Longitudinal Water Penetration Resistance Tests on Longitudinal Water Blocked Cables (revision of ANSI ICEA T-34-664-2014): 6/7/2018

NEMA (ASC C80) (National Electrical Manufacturers Association)

New Standard

ANSI C80.6-2018, Electrical Intermediate Metal Conduit (new standard): 6/7/2018

NSF (NSF International)**Revision**

ANSI/NSF 2-2018 (i28r1), Food Equipment (revision of ANSI/NSF 2-2016): 6/4/2018

ANSI/NSF 41-2018 (i8r2), Non-Liquid Saturated Treatment Systems (revision of ANSI/NSF 41-2016): 6/8/2018

ANSI/NSF 49-2018 (i121r1), Biosafety Cabinetry: Design, Construction, Performance, and Field Certification (revision of ANSI/NSF 49-2016): 5/28/2018

SCTE (Society of Cable Telecommunications Engineers)**Revision**

ANSI/SCTE 23-3-2017, DOCSIS 1.1 Part 3: Operations Support System Interface (revision of ANSI/SCTE 23-3-2010): 6/11/2018

SPRI (Single Ply Roofing Industry)**Revision**

ANSI/SPRI VR-1-2018, Procedure for Investigating Resistance Root or Rhizome Penetration on Vegetative Roofs (revision of ANSI/GRHC/SPRI VR-1-2011): 6/11/2018

UL (Underwriters Laboratories, Inc.)**Reaffirmation**

* ANSI/UL 299-2012 (R2018), Standard for Safety for Dry Chemical Fire Extinguishers (reaffirmation of ANSI/UL 299-2012): 6/8/2018

ANSI/UL 443-2008 (R2018), Standard for Safety for Steel Auxiliary Tanks for Oil-Burner Fuel (reaffirmation of ANSI/UL 443-2008 (R2013)): 5/30/2018

* ANSI/UL 626-2012 (R2018), Standard for Safety for Water Fire Extinguishers (reaffirmation of ANSI/UL 626-2012): 6/8/2018

ANSI/UL 1072-2013 (R2018), Standard for Safety for Medium-Voltage Power Cables (reaffirmation of ANSI/UL 1072-2013): 5/30/2018

Revision

ANSI/UL 66-2018, Standard for Safety for Fixture Wire (revision of ANSI/UL 66-2011 (R2016)): 6/8/2018

ANSI/UL 94-2018, Standard for Safety for Tests for Flammability of Plastic Materials for Parts in Devices and Appliances (revision of ANSI/UL 94-2017): 5/30/2018

ANSI/UL 147A-2018, Standard for Safety for Nonrefillable (Disposable) Type Fuel Gas Cylinder Assemblies (revision of ANSI/UL 147A-2009 (R2013)): 6/6/2018

ANSI/UL 360-2018, Standard for Safety for Liquid-Tight Flexible Metal Conduit (revision of ANSI/UL 360-2015): 5/18/2018

ANSI/UL 508C-2018, Standard for Safety for Power Conversion Equipment (revision of ANSI/UL 508C-2016): 6/11/2018

ANSI/UL 508C-2018a, Standard for Safety for Power Conversion Equipment (revision of ANSI/UL 508C-2016): 6/11/2018

ANSI/UL 508C-2018b, Standard for Safety for Power Conversion Equipment (revision of ANSI/UL 508C-2016): 6/11/2018

ANSI/UL 773A-2018, Standard for Safety for Nonindustrial Photoelectric Switches for Lighting Control (revision of ANSI/UL 773A-2016): 5/25/2018

* ANSI/UL 858-2018, Standard for Household Electric Ranges (revision of ANSI/UL 858-2017): 6/4/2018

ANSI/UL 1069-2018, Standard for Safety for Hospital Signaling and Nurse Call Equipment (revision of ANSI/UL 1069-2017): 6/8/2018

ANSI/UL 2157-2018, Standard for Safety for Electric Clothes Washing Machines and Extractors (Proposal dated 1-19-18) (revision of ANSI/UL 2157-2015): 5/28/2018

* ANSI/UL 2157-2018a, Standard for Safety for Electric Clothes Washing Machines and Extractors (Proposal dated 10-27-17) (revision of ANSI/UL 2157-2015): 5/28/2018

* ANSI/UL 2157-2018b, Standard for Safety for Electric Clothes Washing Machines and Extractors (Proposal dated 4-28-17) (revision of ANSI/UL 2157-2015): 5/28/2018

ANSI/UL 61800-5-1-2018b, Standard for Safety for Adjustable Speed Electrical Power Drive Systems - Part 5-1: Safety Requirements - Electrical, Thermal and Energy (revision of ANSI/UL 61800-5-1-2017): 6/11/2018

ANSI/UL 61800-5-1-2018a, Standard for Safety for Adjustable Speed Electrical Power Drive Systems - Part 5-1: Safety Requirements - Electrical, Thermal and Energy (revision of ANSI/UL 61800-5-1-2017): 6/11/2018

ANSI/UL 61800-5-1-2018, Standard for Safety for Adjustable Speed Electrical Power Drive Systems - Part 5-1: Safety Requirements - Electrical, Thermal and Energy (revision of ANSI/UL 61800-5-1-2017): 6/11/2018

VITA (VMEbus International Trade Association (VITA))**New Standard**

ANSI/VITA 48.4-2018, Liquid Flow Through VPX Plug-In Module Standard (new standard): 6/8/2018

Project Initiation Notification System (PINS)

ANSI Procedures require notification of ANSI by ANSI-accredited standards developers (ASD) of the initiation and scope of activities expected to result in new or revised American National Standards (ANS). Early notification of activity intended to reaffirm or withdraw an ANS and in some instances a PINS related to a national adoption is optional. The mechanism by which such notification is given is referred to as the PINS process. For additional information, see clause 2.4 of the ANSI Essential Requirements: Due Process Requirements for American National Standards.

Following is a list of proposed actions and new ANS that have been received recently from ASDs. Please also review the section in Standards Action entitled "American National Standards Maintained Under Continuous Maintenance" for additional or comparable information with regard to standards maintained under the continuous maintenance option. Use the following Public Document Library url to access PDF & EXCEL reports of approved & proposed ANS. [List of Approved and Proposed ANS](#)

Directly and materially affected interests wishing to receive more information or to submit comments are requested to contact the standards developer directly within 30 days of the publication of this announcement.

AAFS (American Academy of Forensic Sciences)

Contact: *Teresa Ambrosius, (719) 453-1036, tambrosius@aafs.org
410 North 21st Street, Colorado Springs, CO 80904*

BSR/ASB Std 080-201x, Standard for Training to Perform Forensic DNA Reporting and Review (new standard)

Stakeholders: Forensic DNA laboratory practitioners, criminal justice system end-users.

Project Need: Training programs for forensic DNA laboratories based on this standard will provide more effective training and aid consistent reporting and review among laboratory personnel.

This standard provides the minimum training requirements for analysts: (1) Preparing forensic DNA reports and/or notifications, and (2) performing technical and/or administrative reviews on forensic DNA case records and reports.

API (American Petroleum Institute)

Contact: *Sally Goodson, (202) 682-8130, goodsons@api.org
1220 L Street, NW, Washington, DC 20005*

BSR/API MPMS Chapter 8.6-201x, Standard Practice for Continuous and Intermittent Sampling and Handling of Liquefied Natural Gas (national adoption with modifications of ISO 8943-2007 Sampling of Liquefied Natural Gas)

Stakeholders: Relevant oil and gas industry organizations that buy, sell, and/or transport liquified natural gas.

Project Need: API does not have a current standard that covers the application and detail of liquefied natural gas (LNG) sampling. The increase in the export and import of LNG requires a specific standard that will cover the details in sampling and handling of LNG. The intent of this standard is to provide the user-specific, detailed guidelines and instructions in order to design and apply LNG sampling systems.

This standard specified methods for the continuous and intermittent sampling of LNG while it is being transferred through an LNG transfer line.

ASABE (American Society of Agricultural and Biological Engineers)

Contact: *Jean Walsh, (269) 932-7027, walsh@asabe.org
2950 Niles Road, Saint Joseph, MI 49085*

BSR/ASABE S620.1 MONYEAR-201x, Safety for Anhydrous Ammonia Application Equipment (revision and redesignation of ANSI/ASABE S620-MAR2017)

Stakeholders: Manufacturers and providers of anhydrous ammonia applicators, NH₃ distribution systems, electronic control systems, hitching and coupling systems, nurse tank chassis, and NH₃ delivery components; distributors and retailers that assemble and integrate system pieces for customer use; applicator and nurse tank owners and operators; industry training and safety groups, cooperative extension specialists, insurance companies.

Project Need: This revision will align and clarify terminology and language at various points in the standard with existing standards if applicable, further define plumbing for multi-tank systems, front mechanically secure point, and nurse tank hose attachment, and length and applicator and nurse tank hitching systems currently found in Annex 1-3.

This standard establishes the safety requirements for implements of husbandry used in the local transport and application of anhydrous ammonia for agricultural fertilizer. This standard does not cover bulk storage and handling equipment, manufacture of, or over-the-road bulk transport equipment (other than implements of husbandry) for anhydrous ammonia.

ASME (American Society of Mechanical Engineers)

Contact: *Mayra Santiago, (212) 591-8521, ansibox@asme.org*
Two Park Avenue, New York, NY 10016-5990

BSR/ASME B40.100-201x, Pressure Gauges and Gauge Attachments (revision of ANSI/ASME B40.100-2013)

Stakeholders: Manufacturers, users.

Project Need: The Standard will be revised to bring it up to date to current business practices and to harmonize all the different chapters within the Standard.

This standard addresses Pressure Indicating Dial Type - Elastic Element Gauges, Diaphragm Seals, Snubbers, Pressure Limiter Valves, and Pressure Digital Indicating Gauges. These individual standards provide terminology and definitions, dimensions, safety, construction and installation issues, test procedures, and general recommendations.

BSR/ASME B40.200-200x, Thermometers, Direct Reading and Remote Reading (revision of ANSI/ASME B40.200-2008 (R2013))

Stakeholders: Manufacturers, users.

Project Need: The Standard will be revised to bring it up to date to current business practices and to harmonize all the different chapters within the Standard.

This Standard is confined to analog, dial-type bimetallic actuated thermometers utilizing helical bimetallic elements that mechanically sense temperature and indicate it by means of a pointer moving over a scale. It also covers analog, dial-type filled system thermometers, utilizing elastic elements that enable the mechanically converted thermal energy to indicate temperature by means of a pointer moving over a scale. Third, it also covers analog, liquid-in-glass industrial-type thermometers for industrial applications that sense process temperature by means of the expansion of the liquid within the glass thermometer bulb. And last, this Standard covers metallic thermowells for thermometers and electrical temperature sensors. Thermowells protect bulbs from excessive temperatures, excessive pressures, and corrosive attack by the process medium, and against structural damage caused by fluid-velocity-induced vibration.

BSR/ASME B89.4.19-201x, Performance Evaluation of Laser Based Spherical Coordinate Measurement Systems (revision of ANSI/ASME B89.4.19-2006 (R2015))

Stakeholders: Metrology calibration labs, users, manufacturers, aerospace, academia.

Project Need: Standard is being revised to reflect change in technology.

This Standard prescribes methods for the performance evaluation of laser-based spherical coordinate measurement systems and provides a basis for performance comparisons among such systems.

BSR/ASME MBE-1-200x, Model Based Enterprise (new standard)

Stakeholders: Anyone (industry, government, and academia) focused on design and manufacturing (e.g., aerospace, automotive, Department of Defense, medical heavy equipment, etc). Provide rules, guidance, and examples for the creation, use and reuse of model-based datasets, data models, and related topics within a model-based enterprise (MBE).

Project Need: Industries (academia, private industry, government, etc.) are advancing in the use of digital tools for product design, documentation and most importantly, manufacturing.

Provide rules, guidance, and examples for the creation, use, and reuse of model-based datasets, data models, and related topics within a model-based enterprise (MBE).

ASSP (ASC A10) (American Society of Safety Professionals)

Contact: *Lauren Bauerschmidt, (847) 768-3475, LBauerschmidt@assp.org*
520 N. Northwest Hwy., Park Ridge, IL 60068

BSR/ASSP A10.18-201x, Safety Requirements for Temporary Roof and Floor Holes, Wall Openings, Stairways, and Other Unprotected Edges in Construction and Demolition Operations (revision and redesignation of ANSI/ASSE A10.18-2007 (R2012))

Stakeholders: Occupational safety and health professionals in construction work areas.

Project Need: Based upon the consensus of the A10 Committee.

This standard prescribes rules and establishes minimum safety requirements for the protection of employees and the public from hazards arising out of or associated with temporary roof and floor holes, wall openings, stairways, and other unprotected sides and edges, roofs, during construction and demolition activities. This standard applies only to those instances when the leading edge work is inactive and is not currently under construction and is, therefore, considered an unprotected side and edge.

BSR/ASSP A10.23-201x, Safety Requirements for the Installation of Drilled Shafts (revision and redesignation of ANSI/ASSE A10.23-2014)

Stakeholders: Occupational safety and health professionals in construction work areas.

Project Need: Based upon the consensus of the A10 Committee.

This standard establishes safety requirements for the installation of drilled shafts during construction and demolition operations.

ASTM (ASTM International)

Contact: *Laura Klineburger, (610) 832-9696, accreditation@astm.org
100 Barr Harbor Drive, West Conshohocken, PA 19428-2959*

BSR/ASTM WK63724-201x, Reinstatement of F1533-01(2009), Standard Specification for Deformed Polyethylene (PE) Liner (new standard)

Stakeholders: Olefin-Based Pipe industry.

Project Need: Revisions could not get approved in time and now needed to reinstate the standard.

Revisions could not get approved in time and are now needed to reinstate the standard.

BSR/ASTM WK63727-201x, Standard Practice for Qualification of a Combination of Squeeze Tool, Pipe, and Squeeze-Off Procedures to Avoid Long-Term Damage in Polyethylene (PE) Gas Pipe (new standard)

Stakeholders: Gas industry.

Project Need: A revision that could not get approved now needs to be reinstated with revision. The squeeze-off process is commonly used on pipe used in various applications such as gas, water, oil gathering, process water, geothermal, and other applications. Recently, state regulators have been pushing back on the use of squeeze-off because these other applications are not stated in the scope of the three ASTM standards that govern squeeze-off.

This project is to add these piping applications to the scope and body of F1563-11 so that squeeze-off can continue to be allowed in these other applications.

CRRC (Cool Roof Rating Council)

Contact: *Sarah Schneider, (503) 606-8448 EXT 502, sarah@coolroofs.org
2435 N Lombard Street, Portland, OR 97217*

BSR/CRRC S100-201x, Standard Test Methods for Determining Radiative Properties of Materials (revision of ANSI/CRRC S100-2016)

Stakeholders: Roofing manufacturers and sellers; roofing specifiers; architects; contractors; building owners and facility managers; testing laboratories; consultants and engineers; code bodies; building officials.

Project Need: A periodic update of ANSI/CRRC S100 is needed.

ANSI/CRRC S100 covers specimen preparation and test methods for determining the initial and aged solar reflectance and thermal emittance of roofing products. The CRRC will be forming its consensus body through July 1, 2018. Interested applicants can visit <http://coolroofs.org/> or email sarah@coolroofs.org for more information.

PDA (Parenteral Drug Association)

Contact: *Christine Alston-Roberts, (301)-656-5900-ext.106, roberts@pda.org
Bethesda Towers, 4350 East-West Highway, Bethesda, MD 20814*

BSR/PDA Standard 01-201x, Enhanced Purchasing Controls to Support the Bio-Pharmaceutical, Pharmaceutical, Medical Devices and Combination Products Industries (new standard)

Stakeholders: Producer interest members (ex: manufacturers, those involved in supply chains, employees of test labs or commercial labs, etc.).
Regulatory interest members (ex: those representing federal, state, local, foreign, or other government entities).

Project Need: This proposed American National Standard (ANS) is intended to address the challenges associated with purchasing/procuring/sourcing organizations and steps to make them more effective in preventing substandard or adulterated materials from entering the market and potentially harming patients.

Historically, purchasing/procuring/sourcing organizations have not been under routine regulatory GMP scrutiny. In rare cases when purchasing controls were evaluated, it occurred by inspecting a quality unit or manufacturing site, which was held accountable. For example, a typical inspection observation related to these issues would begin with "The Quality Unit failed to...". Current quality management systems can be made more effective in preventing substandard or adulterated materials from entering the market place and potentially harming patients by holding the appropriate individuals within a company or organization accountable for making the right purchasing decisions. Enhanced controls are aimed at placing accountability with the proper individual within a firm, and to put those purchasing/procuring/sourcing organizations under regulatory scrutiny via routine regulatory inspections.

BSR/PDA Standard 02-201x, Cryopreservation of Cells for Use in Cell Therapies and Regenerative Medicine Manufacturing (new standard)

Stakeholders: Producer interest stakeholders: Individuals in this interest category include manufacturers, those involved in supply chains, employees of test labs or commercial labs, etc.

Project Need: This proposed American National Standard (ANS) is intended to:

- address the challenges associated with maintaining the viable recovery and functionality of cellular therapies and tissue products;
- discuss the benefits and considerations of low-temperature biopreservation;
- outline biopreservation best practices for users, and
- propose considerations for incorporating biopreservation best practices into a GMP cell therapy product.

An Introduction and Best Practices Approach on how to prepare, cryopreserve, and recover cells, cell lines, and tissue for use in cell therapies and regenerative medicine manufacturing.

SCTE (Society of Cable Telecommunications Engineers)

Contact: *Kim Cooney, (800) 542-5040, kcooney@scte.org*
140 Philips Rd, Exton, PA 19341

BSR/SCTE 194-2-201x, DTS-HD Audio System - Transport Specification for Cable Television (revision of ANSI/SCTE 194-2-2014)

Stakeholders: Cable Telecommunications industry.

Project Need: Update to current technology.

This document describes the carriage of DTS-HD audio in MPEG-2 systems. The descriptor necessary to signal DTS-HD audio is defined in this document. Multiplexing and transport for cable using MPEG-2 systems are defined in SCTE 54. Coding constraints for DTS-HD audio elementary streams are defined in SCTE 194-1.

SPRI (Single Ply Roofing Industry)

Contact: *Linda King, (781) 647-7026, info@spri.org*
465 Waverley Oaks Road, Suite 421, Waltham, MA 02452

BSR/SPRI WD-1-201x, Wind Design Standard Practice for Roofing Assemblies (revision of ANSI/SPRI WD-1-2014)

Stakeholders: Roofing design professionals, architects, consultants and roofing contractors.

Project Need: The document is in need of updating due to the issuance of the ASCE 7-16 Standard.

This Wind Design Standard Practice provides general building design considerations as well as a methodology for selecting an appropriate roofing system assembly to meet the rooftop design wind uplift pressures that are calculated in accordance with the current version of the International Building Code (IBC). This Standard Practice is appropriate for non-ballasted Built-Up, Modified Bitumen, and Single-Ply roofing system assemblies installed over any type of roof deck.

TCIA (ASC A300) (Tree Care Industry Association)

Contact: *Amy Tetreault, (603) 314-5380, atetreault@tcia.org*
136 Harvey Rd # 101, Londonderry, NH 03053

BSR A300 Part 3-201x, Tree Care Operations - Tree, Shrub, and Other Woody Plant Management - Standard Practices (Supplemental Support Systems) (revision of ANSI A300 Part 3-2013)

Stakeholders: Tree Care industry, Green industry, arborists, Land Care industry, landscape architects, property managers, utilities, urban planners, consumers, government agencies.

Project Need: Revision needed to review and incorporate changes in industry standard practices, as appropriate, since the approval of the current standard.

A300 (Part 3) Supplemental Support Systems standards are performance standards for the installation of cabling, bracing, guying, and prop systems in trees and woody shrubs. It is a guide for drafting supplemental support system specifications for consumers as well as Federal, state, municipal, and private authorities including property owners, property managers, and utilities.

BSR A300 Part 8-201x, Tree Care Operations - Tree, Shrub, and Other Woody Plant Maintenance - Standard Practices (Root Management and Soil Modification) (revision of ANSI A300 Part 8-2013)

Stakeholders: Tree Care industry, Green industry, arborists, Land Care industry, landscape architects, property managers, utilities, urban planners, consumers, government agencies.

Project Need: Revision needed to review and incorporate changes in industry standard practices, as appropriate, since the approval of the current standard.

A300 (Part 8) Root Management standards are performance standards for the care and maintenance of trees, shrubs, and other woody plants during root management and soil modification operations.

UL (Underwriters Laboratories, Inc.)

Contact: *Jeff Prusko, (847) 664-3416, jeffrey.prusko@ul.com*
 333 Pfingsten Road, Northbrook, IL 60062-2096

BSR/UL 2152-201x, Standard for Safety for Special Purpose Nonmetallic Containers and Tanks for Specific Combustible or Noncombustible Liquids (new standard)

Stakeholders: Manufacturers of special purpose nonmetallic containers and tanks (vessels) for specific aboveground use applications for combustible or non-combustible liquids as indicated for special purpose types, including liquid chemical containers and tanks designed for stationary storage of combustible or non-combustible liquids in non-residential applications, and cooking oil tanks designed for storage of cooking oils typically found in commercial food preparing applications having engineered transfer systems.

Project Need: To obtain national recognition of a standard covering special purpose nonmetallic containers and tanks (vessels) for specific aboveground use applications for combustible or non-combustible liquids as indicated for special purpose types, including liquid chemical containers and tanks designed for stationary storage of combustible or non-combustible liquids in non-residential applications, and cooking oil tanks designed for storage of cooking oils typically found in commercial food preparing applications having engineered transfer systems.

These requirements cover special-purpose nonmetallic containers and tanks (vessels) for specific aboveground use applications for combustible or non-combustible liquids as indicated for each special-purpose type, which are intended to address the specific designs, features, limitations, use factors, and other unique characteristics of each type. The basic types of different special-purpose vessels covered by this standard are: (a) Liquid Chemical Containers and Tanks designed for stationary storage of combustible or non-combustible liquids in non-residential applications, and are intended to be used in accordance with NFPA 30, Chapter 9 (Storage of Liquids in Containers - General Requirements), Section 9.4 (Acceptable Containers and Tanks). Liquid chemical tanks are limited to the specific liquid(s) or family of similar liquids and application(s) to which they are rated under the evaluation; (b) Cooking Oil Tanks designed for storage of cooking oils and fats typically found in restaurant or similar commercial food-preparing applications having engineered transfer systems. These tanks are intended for either delivery of fresh oil and/or collection of waste oils by trained persons using service trucks with pressure or vacuum pumps through piping networks. These tanks are limited to Class IIIB oils and fats, and are intended to be installed in cooking oil storage systems used in commercial kitchens, in accordance with NFPA 1, Chapter 66.19.7 or NFPA 30, Chapter 19.7; (c) Lube Oil Tanks designed for storage, dispensing and collection of Class IIIB motor oils (such as lubricating, transmission, cooling, etc.), working oils (such as hydraulic, brake, steering, cutting, etc.), and other petroleum or synthetic oils with similar chemical and physical properties used in equipment applications; and (d) Vehicle Fluid Tanks for storage, dispensing and collection of non-combustible fluids such as antifreeze/coolants (ethylene-glycol and water mixtures), windshield washer (alcohol, water, and detergent mixtures), DEF (nom 1/3 urea and 2/3 water diesel exhaust solution), and other optional fluid types typically used in vehicles.

VITA (VMEbus International Trade Association (VITA))

Contact: *Jing Kwok, (602) 281-4497, jing.kwok@vita.com*
 929 W. Portobello Avenue, Mesa, AZ 85210

BSR/VITA 66.1-201x, Optical Interconnect on VPX - MT Variant (revision of ANSI/VITA 66.1-2012)

Stakeholders: Manufacturers and users of embedded VPX modules.

Project Need: Standardize MT variant optical interconnect for VPX modules.

The objective of this standard is to define a family of blind-mate Fiber Optic interconnects for use with VPX backplanes and plug-in modules.

BSR/VITA 67.0-201x, Coaxial Interconnect on VPX - Base Standard (revision of ANSI/VITA 67.0-2012)

Stakeholders: Manufacturers and users of embedded VPX modules.

Project Need: Develop a standard for coaxial interconnects on VPX modules.

The objective of this standard is to define a family of blind-mate analog interconnects for use with VITA 46 backplanes and plug-in modules.

American National Standards Maintained Under Continuous Maintenance

The ANSI Essential Requirements: Due Process Requirements for American National Standards provides two options for the maintenance of American National Standards (ANS): periodic maintenance (see clause 4.7.1) and continuous maintenance (see clause 4.7.2). Continuous maintenance is defined as follows:

The standard shall be maintained by an accredited standards developer. A documented program for periodic publication of revisions shall be established by the standards developer. Processing of these revisions shall be in accordance with these procedures. The published standard shall include a clear statement of the intent to consider requests for change and information on the submittal of such requests. Procedures shall be established for timely, documented consensus action on each request for change and no portion of the standard shall be excluded from the revision process. In the event that no revisions are issued for a period of four years, action to reaffirm or withdraw the standard shall be taken in accordance with the procedures contained in the ANSI Essential Requirements.

The Executive Standards Council (ExSC) has determined that for standards maintained under the Continuous Maintenance option, separate PINS announcements are not required. The following ANSI Accredited Standards Developers have formally registered standards under the Continuous Maintenance option

- AAMI (Association for the Advancement of Medical Instrumentation)
- AARST (American Association of Radon Scientists and Technologists)
- AGA (American Gas Association)
- AGSC-AGRSS (Auto Glass Safety Council)
- ASC X9 (Accredited Standards Committee X9, Incorporated)
- ASHRAE (American Society of Heating, Refrigerating and Air-Conditioning Engineers, Inc.)
- ASME (American Society of Mechanical Engineers)
- ASTM (ASTM International)
- GBI (Green Building Initiative)
- HL7 (Health Level Seven)
- IES (Illuminating Engineering Society)
- MHI (Material Handling Industry)
- NAHBRC (NAHB Research Center, Inc.)
- NBBPVI (National Board of Boiler and Pressure Vessel Inspectors)
- NCPDP (National Council for Prescription Drug Programs)
- NEMA (National Electrical Manufacturers Association)
- NISO (National Information Standards Organization)
- NSF (NSF International)
- PRCA (Professional Ropes Course Association)
- RESNET (Residential Energy Services Network, Inc.)
- SAE (SAE International)
- TCNA (Tile Council of North America)
- TIA (Telecommunications Industry Association)
- UL (Underwriters Laboratories, Inc.)

To obtain additional information with regard to these standards, including contact information at the ANSI Accredited Standards Developer, please visit ANSI Online at www.ansi.org/asd, select "Standards Activities," click on "Public Review and Comment" and "American National Standards Maintained Under Continuous Maintenance." This information is also available directly at www.ansi.org/publicreview

Alternatively, you may contact the Procedures & Standards Administration department (PSA) at psa@ansi.org or via fax at 212-840-2298. If you request that information be provided via E-mail, please include your E-mail address; if you request that information be provided via fax, please include your fax number. Thank you.

ANSI-Accredited Standards Developers Contact Information

The addresses listed in this section are to be used in conjunction with standards listed in PINS, Call for Comment and Final Actions. This section is a list of developers who have submitted standards for this issue of *Standards Action* – it is not intended to be a list of all ANSI-Accredited Standards Developers. Please send all address corrections to Standards Action Editor at standact@ansi.org.

<p>AAFS American Academy of Forensic Sciences 410 North 21st Street Colorado Springs, CO 80904 Phone: (719) 453-1036 Web: www.aafs.org</p>	<p>ASME American Society of Mechanical Engineers Two Park Avenue New York, NY 10016-5990 Phone: (212) 591-8521 Fax: (212) 591-8501 Web: www.asme.org</p>	<p>MHI Material Handling Industry 8720 Red Oak Boulevard Suite 201 Charlotte, NC 28217 Phone: (704) 714-8755 Fax: (704) 676-1199 Web: www.mhi.org</p>	<p>PDA Parenteral Drug Association Bethesda Towers, 4350 East-West Highway Bethesda, MD 20814 Phone: (301) -656-5900-ext.106 Web: www.pda.org</p>
<p>ACCA Air Conditioning Contractors of America 2800 Shirlington Road Suite 300 Arlington, VA 22206 Phone: (703) 824-8868 Web: www.acca.org</p>	<p>ASSP (ASC A10) American Society of Safety Professionals 520 N. Northwest Hwy. Park Ridge, IL 60068 Phone: (847) 768-3475 Web: www.asse.org</p>	<p>NECA National Electrical Contractors Association 3 Bethesda Metro Center Suite 1100 Bethesda, MD 20814 Phone: (301) 215-4544 Web: www.neca-neis.org</p>	<p>SCTE Society of Cable Telecommunications Engineers 140 Philips Rd Exton, PA 19341 Phone: (800) 542-5040 Fax: (800) 542-5040 Web: www.scte.org</p>
<p>APCO Association of Public-Safety Communications Officials-International 351 N. Williamson Boulevard Daytona Beach, FL 32114 Phone: (920) 579-1153 Web: www.apcolntl.org</p>	<p>ASTM ASTM International 100 Barr Harbor Drive West Conshohocken, PA 19428-2959 Phone: (610) 832-9696 Web: www.astm.org</p>	<p>NEMA (ASC C136) National Electrical Manufacturers Association 1300 North 17th Street Suite 900 Rosslyn, VA 22209 Phone: (703) 841-3277 Fax: (703) 841-3378 Web: www.nema.org</p>	<p>SPRI Single Ply Roofing Industry 465 Waverley Oaks Road Suite 421 Waltham, MA 02452 Phone: (781) 647-7026 Fax: (781) 647-7222 Web: www.spri.org</p>
<p>API American Petroleum Institute 1220 L Street, NW Washington, DC 20005 Phone: (202) 682-8130 Fax: (202) 962-4797 Web: www.api.org</p>	<p>AWS American Welding Society 8669 NW 36th Street Suite #130 Miami, FL 33166-6672 Phone: (800) 443-9353 Web: www.aws.org</p>	<p>NEMA (ASC C78) National Electrical Manufacturers Association 1300 N 17th St Rosslyn, VA 22209 Phone: 703-841-3262 Web: www.nema.org</p>	<p>TCIA (ASC A300) Tree Care Industry Association 136 Harvey Rd # 101 Londonderry, NH 03053 Phone: (603) 314-5380 Fax: (603) 314-5386 Web: www.treecareindustry.org</p>
<p>ASABE American Society of Agricultural and Biological Engineers 2950 Niles Road Saint Joseph, MI 49085 Phone: (269) 932-7027 Fax: (269) 429-3852 Web: www.asabe.org</p>	<p>CRRC Cool Roof Rating Council 2435 N Lombard Street Portland, OR 97217 Phone: (503) 606-8448 EXT 502 Web: www.coolroofs.org</p>	<p>NEMA (ASC C8) National Electrical Manufacturers Association 1300 North 17th Street Rosslyn, VA 22209 Phone: (703) 841-3278 Fax: (703) 841-3398 Web: www.nema.org</p>	<p>UL Underwriters Laboratories, Inc. 333 Pfingsten Road Northbrook, IL 60062-2096 Phone: (847) 664-3416 Fax: (847) 313-3416 Web: www.ul.com</p>
<p>ASX 9 Accredited Standards Committee X9, Incorporated 275 West Street Suite 107 Annapolis, MD 21401 Phone: (410) 267-7707 Web: www.x9.org</p>	<p>CSA CSA Group 8501 E. Pleasant Valley Road Cleveland, OH 44131 Phone: (216) 524-4990 Fax: (216) 520-8979 Web: www.csagroup.org</p>	<p>NEMA (ASC C80) National Electrical Manufacturers Association 1300 North 17th Street Suite 900 Rosslyn, VA 22209 Phone: (703) 841-3288 Fax: 703.841.3388 Web: www.nema.org</p>	<p>VITA VMEbus International Trade Association (VITA) 929 W. Portobello Avenue Mesa, AZ 85210 Phone: (602) 281-4497 Web: www.vita.com</p>
<p>ASHRAE American Society of Heating, Refrigerating and Air-Conditioning Engineers, Inc. 1791 Tullie Circle NE Atlanta, GA 30329 Phone: (678) 539-1111 Fax: (678) 539-2111 Web: www.ashrae.org</p>	<p>FM FM Approvals 1151 Boston-Providence Turnpike Norwood, MA 02062 Phone: (781) 255-4813 Fax: (781) 762-9375 Web: www.fmglobal.com</p> <p>HI Hydraulic Institute 6 Campus Drive Parsippany, NJ 07054 Phone: (973) 267-9700 EXT 115 Web: www.pumps.org</p>	<p>NSF NSF International 789 N. Dixboro Road Ann Arbor, MI 48105-9723 Phone: (734) 827-6866 Web: www.nsf.org</p>	



ISO & IEC Draft International Standards

This section lists proposed standards that the International Organization for Standardization (ISO) and the International Electrotechnical Commission (IEC) are considering for approval. The proposals have received substantial support within the technical committees or subcommittees that developed them and are now being circulated to ISO and IEC members for comment and vote. Standards Action readers interested in reviewing and commenting on these documents should order copies from ANSI.

Comments

Comments regarding ISO documents should be sent to ANSI's ISO Team (isot@ansi.org); comments on ISO documents must be submitted electronically in the approved ISO template and as a Word document as other formats will not be accepted.

Those regarding IEC documents should be sent to Tony Zertuche, General Secretary, USNC/IEC, at ANSI's New York offices (tzertuche@ansi.org). The final date for offering comments is listed after each draft.

Ordering Instructions

ISO and IEC Drafts can be made available by contacting ANSI's Customer Service department. Please e-mail your request for an ISO or IEC Draft to Customer Service at sales@ansi.org. When making your request, please provide the date of the Standards Action issue in which the draft document you are requesting appears.

ISO Standards

AIRCRAFT AND SPACE VEHICLES (TC 20)

ISO/DIS 11231, Space systems - Probabilistic risk assessment (PRA) - 6/29/2018, \$82.00

CLINICAL LABORATORY TESTING AND IN VITRO DIAGNOSTIC TEST SYSTEMS (TC 212)

ISO/DIS 35001, Biorisk management for laboratories and other related organisations - 8/25/2018, \$88.00

EARTH-MOVING MACHINERY (TC 127)

ISO/DIS 5010, Earth-moving machinery - Wheeled machines - Steering requirements - 8/24/2018, \$77.00

FLOOR COVERINGS (TC 219)

ISO/DIS 13746, Textile floor coverings - Guidelines for installation and use on stairs - 6/29/2018, \$40.00

GAS CYLINDERS (TC 58)

ISO 11118/DAMd1, Gas cylinders - Non-refillable metallic gas cylinders - Specification and test methods- Amendment 1 - 11/3/2001, \$33.00

ISO/DIS 11513, Gas cylinders - Refillable welded steel cylinders containing materials for sub-atmospheric gas packaging (excluding acetylene) - Design, construction, testing, use and periodic inspection - 9/2/2018, \$82.00

GRAPHIC TECHNOLOGY (TC 130)

ISO/DIS 16684-1, Graphic technology - Extensible metadata platform (XMP) specification - Part 1: Data model, serialization and core properties - 8/26/2018, \$119.00

HYDROMETRIC DETERMINATIONS (TC 113)

ISO/DIS 18320, Hydrometry - Determination of liquid flow in open channels - 8/24/2018, \$112.00

INTERNAL COMBUSTION ENGINES (TC 70)

ISO/DIS 2710-2, Reciprocating internal combustion engines - Vocabulary - Part 2: Terms for engine maintenance - 7/1/2018, \$62.00

LEATHER (TC 120)

ISO/DIS 22244, Leather - Raw Hides - Guidelines for Preservation of Hides - 9/1/2018, \$33.00

MATERIALS, EQUIPMENT AND OFFSHORE STRUCTURES FOR PETROLEUM AND NATURAL GAS INDUSTRIES (TC 67)

ISO/DIS 13679, Petroleum and natural gas industries - Procedures for testing casing and tubing connections - 8/24/2018, \$33.00

PAINTS AND VARNISHES (TC 35)

ISO/DIS 2431, Paints and varnishes - Determination of flow time by use of flow cups - 8/26/2018, \$67.00

ISO/DIS 1518-1, Paints and varnishes - Determination of scratch resistance - Part 1: Constant-loading method - 8/26/2018, \$40.00

ISO/DIS 1518-2, Paints and varnishes - Determination of scratch resistance - Part 2: Variable-loading method - 8/26/2018, \$40.00

ISO/DIS 22516, Paints and varnishes - Practical determination of non-volatile and volatile matter content during application - 8/26/2018, \$46.00

ISO/DIS 22518, Paints and varnishes - Determination of solvents in water-thinnable coating materials - Gas-chromatographic method - 8/30/2018, \$62.00

ISO/DIS 22557, Paints and varnishes - Scratch test using a spring-loaded pen - 8/26/2018, \$62.00

ISO/DIS 11124-5, Preparation of steel substrates before application of paints and related products - Specifications for metallic blast-cleaning abrasives - Part 5: Cut steel wire - 8/26/2018, \$46.00

ISO/DIS 22553-1, Paints and varnishes - Electro-deposition coatings - Part 1: Terminology and general principle - 8/26/2018, \$53.00

ISO/DIS 22553-2, Paints and varnishes - Electro-deposition coatings - Part 2: Throwing power - 8/26/2018, \$62.00

ISO/DIS 22553-3, Paints and varnishes - Electro-deposition coatings - Part 3: Compatibility of electro-deposition coating materials with a reference oil - 8/26/2018, \$40.00

ISO/DIS 22553-4, Paints and varnishes - Electro-deposition coatings - Part 4: Compatibility of electro-deposition coating materials with liquid, paste-like and solid foreign materials - 8/26/2018, \$53.00

ISO/DIS 22553-5, Paints and varnishes - Electro-deposition coatings - Part 5: Determination of sieve residue - 8/26/2018, \$33.00

ISO/DIS 22553-6, Paints and varnishes - Electro-deposition coatings - Part 6: Entry marks - 8/26/2018, \$33.00

PETROLEUM PRODUCTS AND LUBRICANTS (TC 28)

ISO 8068/DAmD1, Lubricants, industrial oils and related products (class L) - Family T (Turbines) - Specification for lubricating oils for turbines - Amendment 1: Filterability tests according to ISO 13357-1 and ISO 13357-2 - Requirement related to the stage of the test method - 7/1/2018, \$33.00

PLASTICS (TC 61)

ISO/DIS 179-2, Plastics - Determination of Charpy impact properties - Part 2: Instrumented impact test - 8/27/2018, \$82.00

ISO/DIS 11963, Plastics - Polycarbonate sheets - Types, dimensions and characteristics - 6/29/2018, \$40.00

ISO/DIS 11833-1, Plastics - Unplasticized poly(vinyl chloride) sheets - Types, dimensions and characteristics - Part 1: Sheets of thickness not less than 1 mm - 6/29/2018, \$71.00

PULLEYS AND BELTS (INCLUDING VEEBELTS) (TC 41)

ISO/DIS 2790, Belt drives - V-belts for the automotive industry and corresponding pulleys - Dimensions - 8/27/2018, \$46.00

RUBBER AND RUBBER PRODUCTS (TC 45)

ISO 19385/DAmD1, Rubber and plastics hoses and hose assemblies, wire- or textile-reinforced, for water jetting or water blasting applications - Specification - Amendment 1 - 7/1/2018, \$29.00

SHIPS AND MARINE TECHNOLOGY (TC 8)

ISO/DIS 20233-2, Ships and marine technology - Model test method for propeller cavitation noise evaluation in ship design - Part 2: Noise source localization - 8/24/2018, \$53.00

SMALL CRAFT (TC 188)

ISO/DIS 12215-10, Small craft - Hull construction and scantlings - Part 10: Rig loads and rig attachment in sailing craft - 8/23/2018, \$134.00

STERILIZATION OF HEALTH CARE PRODUCTS (TC 198)

ISO/DIS 11737-2, Sterilization of medical devices - Microbiological methods - Part 2: Tests of sterility performed in the definition, validation and maintenance of a sterilization process - 6/30/2018, \$98.00

SUSTAINABLE DEVELOPMENT IN COMMUNITIES (TC 268)

ISO/DIS 37122, Sustainable development in communities - Indicators for Smart Cities - 6/30/2018, \$146.00

(TC 279)

ISO/DIS 50501, Innovation management - Innovation management system - Guidance - 8/31/2018, \$102.00

TERMINOLOGY (PRINCIPLES AND COORDINATION) (TC 37)

ISO/DIS 12620, Terminology and other language and content resources - Data category specifications - 6/30/2018, \$62.00

TEXTILES (TC 38)

ISO/DIS 22744-1, Textiles and textile product - Critical substances potentially present in components of textile product materials - Determination of organotin compounds - Part 1: Method using gas chromatography - 8/26/2018, \$53.00

TOBACCO AND TOBACCO PRODUCTS (TC 126)

ISO/DIS 9512, Cigarettes - Determination of ventilation - Definitions and measurement principles - 8/30/2018, \$71.00

TRACTORS AND MACHINERY FOR AGRICULTURE AND FORESTRY (TC 23)

ISO/DIS 22868, Forestry and gardening machinery - Noise test code for portable hand-held machines with internal combustion engine - Engineering method (Grade 2 accuracy) - 7/1/2018, \$107.00

ISO/DIS 15886-4, Irrigation equipment - Irrigation sprinklers - Part 4: Test methods for durability - 9/1/2018, \$53.00

TRANSPORT INFORMATION AND CONTROL SYSTEMS (TC 204)

ISO/DIS 19297-1, Intelligent transport systems - Shareable geospatial databases for ITS applications - Part 1: Framework - 9/1/2018, \$53.00

WATER QUALITY (TC 147)

ISO/DIS 22125-1, Water quality - Technetium-99 - Part 1: Test method using liquid scintillation counting - 8/25/2018, \$82.00

ISO/DIS 22125-2, Water quality - Technetium-99 - Part 2: Test method using inductively coupled plasma mass spectrometry (ICP-MS) - 8/26/2018, \$82.00

ISO/IEC JTC 1, Information Technology

ISO/IEC DIS 22243, Information technology - Radio frequency identification for item management - Methods for localization of RFID tags - 6/29/2018, \$62.00

ISO/IEC DIS 19774-1, Information technology - Computer graphics and image processing - Humanoid Animation (H-Anim) - Part 1: Architecture - 8/27/2018, \$77.00

ISO/IEC DIS 19774-2, Information technology - Computer graphics and image processing - Humanoid Animation (H-Anim) - Part 2: Motion capture - 8/27/2018, \$58.00

ISO/IEC/IEEE DIS 21839, Information technology - Systems and software engineering - System of Systems (SoS) considerations in life cycle stages of a system - 7/1/2018, \$102.00

IEC Standards

10/1061/FDIS, IEC 60156 ED3: Insulating liquids - Determination of the breakdown voltage at power frequency - Test method, 2018/7/20

17A/1188/CD, IEC 62271-113 ED1: High-voltage switchgear and controlgear - Alternating current circuit-breakers with intentionally non-simultaneous pole operation, 2018/8/31

21A/660/CD, IEC 61960-4 ED1: Secondary cells and batteries containing alkaline or other non-acid electrolytes - Secondary lithium cells and batteries for portable applications - Part 4: Coin types (button) lithium secondary cells and batteries, 018/8/31

21A/661/NP, PNW 21A-661: Secondary cells and batteries containing alkaline and other non-acid electrolyte - Secondary Lithium ion, Nickel Cadmium, and Nickel Metal Hydride cells and batteries for portable applications - Guidance on environmental aspects, 2018/8/31

23E/1054/CD, IEC 60898-1/AMD1 ED2: Electrical accessories - Circuit-breakers for overcurrent protection for household and similar installations - Part 1: Circuit-breakers for a.c. operation, 2018/8/31

29/996/CD, IEC 60118-0 ED4: Electroacoustics - Hearing aids - Part 0: Measurement of the performance characteristics of hearing aids, 018/8/31

29/997/NP, PNW 29-997: Definition and verification of hearing aid features, 2018/8/31

29/991/CDV, IEC 60118-13 ED5: Electroacoustics - Hearing aids - Part 13: Requirements and methods of measurement for electromagnetic immunity to mobile digital wireless devices, 2018/8/31

- 34C/1389/CD, IEC 61347-2-7/AMD2/FRAG1 ED3: Lamp controlgear - Part 2-7: Particular requirements for battery supplied electronic controlgear for emergency lighting (self-contained), 2018/8/31
- 34D/1382/CD, IEC 60598-2-22/AMD2/FRAG2 ED4: Luminaires - Part 2-22: Particular requirements - Luminaires for emergency lighting, 2018/8/31
- 44/827/CD, IEC 62061 ED2: Safety of machinery - Functional safety of safety-related electrical, electronic and programmable electronic control systems, 2018/8/31
- 46A/1364/CD, IEC 61196-6-5 ED1: Coaxial communication cables - Part 6-5: Detail specification for CATV drop cables with screening class A++, 2018/8/31
- 48B/2667/FDIS, IEC 60512-1 ED5: Connectors for electrical and electronic equipment - Tests and measurements - Part 1: Generic specification, 2018/7/20
- 57/2006/NP, PNW TS 57-2006: Power systems management and associated information exchange - Data and communications security - Part 100-6: Conformance testing for IEC 62351-6 (proposed IEC TS 62351-100-6), 2018/8/31
- 57/2007/NP, PNW TS 57-2007: Power systems management and associated information exchange - Data and communications security - Part 100-4: Conformance testing for IEC 62351-4 (proposed IEC TS 62351-100-4), 2018/8/31
- 62A/1277/NP, PNW 62A-1277: Application of risk management for IT-networks incorporating medical device - Safety, effectiveness and security in the implementation and use of connected medical devices or connected health software - Part 5-1: Activities in the product lifecycle, 2018/8/31
- 64/2285/FDIS, IEC 60364-7-722 ED2: Low-voltage electrical installations - Part 7-722: Requirements for special installations or locations - Supplies for electric vehicles, 2018/7/20
- 68/602/NP, PNW 68-602: Magnetic materials - Part 17: Methods of measurement of the magnetostriction characteristics of electrical steel strip and sheet by means of a single sheet tester and an optical sensor, 2018/8/31
- 82/1442/FDIS, IEC 61853-4 ED1: Photovoltaic (PV) module performance testing and energy rating - Part 4: Standard reference climatic profiles, 2018/7/20
- 82/1441/FDIS, IEC 61853-3 ED1: Photovoltaic (PV) module performance testing and energy rating - Part 3: Energy rating of PV modules, 2018/7/20
- 86A/1873/CD, IEC 60794-1-215 ED1: Optical Fibre Cables - Part 1 -215: Generic specification - Basic optical cable test procedures - Environmental test methods - Cable external freezing test, Method F15, 2018/8/31
- 86B/4134/CD, IEC 61754-35 ED1: Fibre optic interconnecting devices and passive components - Fibre optic connector interfaces - Part 35: Type LSHE connector series for harsh environments, 2018/8/31
- 86C/1533/CD, IEC 62149-3 ED3: Fibre optic active components and devices - Performance standards - Part 3: Modulator-integrated laser diode transmitters for 40-Gbit/s fibre optic transmission systems, 2018/8/31
- 90/407/CD, IEC 61788-26 ED1: Superconductivity - Part 26: Critical current measurement - DC critical current of RE-Ba-Cu-O composite superconductors, 2018/8/31
- 94/435/CD, IEC 62314 ED2: Solid-state relays, 2018/8/31
- 100/3101/CDV, IEC 61937-5/AMD1 ED2: Digital audio - Interface for non-linear PCM encoded audio bitstreams applying IEC 60958 - Part 5: Non-linear PCM bitstreams according to the DTS (Digital Theater Systems) format(s) (TA 4), 2018/8/31
- 110/978/CDV, IEC 62629-12-2 ED1: 3D display devices - Part 12-2: Measuring methods for stereoscopic displays using glasses - Motion blur, 2018/8/31
- 110/991/CD, IEC TR 62595-1-4 ED1: Display lighting unit - Part 1-4: Glass light guide plate, 2018/8/31
- 116/372/NP, PNW 116-372: Electric motor-operated hand-held tools, transportable tools and lawn and garden machinery - Safety - Part 2 -3: Particular requirements for hand-held grinders, disc-type polishers and disc-type sanders, 2018/8/31
- 121A/222/CDV, IEC 60947-5-4/AMD1 ED2: Low-voltage switchgear and controlgear - Part 5-4: Control circuit devices and switching elements - Method of assessing the performance of low-energy contacts - Special tests, 2018/8/31
- 121A/221/CDV, IEC 62026-1 ED3: Low-voltage switchgear and controlgear - Controller-device interfaces (CDIs) - Part 1: General rules, 2018/8/31
- SyCSmartEnergy/89/DTS, IEC TS 62913-2-3 ED1: Generic Smart Grid Requirements - Part 2-3: Domains - Resources connected to the grid related domains, these include Bulk Generation, Distributed Energy Resources, Smart Home / Commercial / Industrial / DR- Customer Energy Management, and Energy Storage, 2018/8/31
- JTC1-SC25/2810/FDIS, ISO/IEC 14763-3/AMD1 ED2: Information technology - Implementation and operation of customer premises cabling - Part 3: Testing of optical fibre cabling - Amendment 1, 018/8/3/
- JTC1-SC25/2812/CD, ISO/IEC 14543-3-10 ED2: Information technology - Home electronic system (HES) architecture - Part 3-10: Wireless short-packet (WSP) protocol optimised for energy harvesting - Architecture and lower layer protocols, 018/8/3/
- JTC1-SC41/45/NP, PNW JTC1-SC41-45: Internet of Things (IoT) - Trustworthiness framework, 2018/8/31



Newly Published ISO & IEC Standards

Listed here are new and revised standards recently approved and promulgated by ISO - the International Organization for Standardization – and IEC – the International Electrotechnical Commission. Most are available at the ANSI Electronic Standards Store (ESS) at www.ansi.org. All paper copies are available from Standards resellers (<http://webstore.ansi.org/faq.aspx#resellers>).

ISO Standards

ACOUSTICS (TC 43)

[ISO 11200/Amd1:2018](#), Acoustics - Noise emitted by machinery and equipment - Guidelines for the use of basic standards for the determination of emission sound pressure levels at a work station and at other specified positions - Amendment 1, \$19.00

AIRCRAFT AND SPACE VEHICLES (TC 20)

[ISO 20780:2018](#), Space systems - Fiber optic components - Design and verification requirements, \$103.00

CLEAN COOKSTOVES AND CLEAN COOKING SOLUTIONS (TC 285)

[ISO 19867-1:2018](#), Clean cookstoves and clean cooking solutions - Harmonized laboratory test protocols - Part 1: Standard test sequence for emissions and performance, safety and durability, \$232.00

COPPER, LEAD AND ZINC ORES AND CONCENTRATES (TC 183)

[ISO 12743:2018](#), Copper, lead, zinc and nickel concentrates - Sampling procedures for determination of metal and moisture content, \$209.00

DENTISTRY (TC 106)

[ISO 10477:2018](#), Dentistry - Polymer-based crown and veneering materials, \$138.00

DOCUMENT IMAGING APPLICATIONS (TC 171)

[ISO 14641:2018](#), Electronic document management - Design and operation of an information system for the preservation of electronic documents - Specifications, \$185.00

GEOTECHNICS (TC 182)

[ISO 17892-12:2018](#), Geotechnical investigation and testing - Laboratory testing of soil - Part 12: Determination of liquid and plastic limits, \$162.00

IMPLANTS FOR SURGERY (TC 150)

[ISO 13019:2018](#), Tissue-engineered medical products - Quantification of sulfated glycosaminoglycans (sGAG) for evaluation of chondrogenesis, \$103.00

INDUSTRIAL AUTOMATION SYSTEMS AND INTEGRATION (TC 184)

[ISO 18828-4:2018](#), Industrial automation systems and integration - Standardized procedures for production systems engineering - Part 4: Key performance indicators (KPIs) in production planning processes, \$185.00

MACHINE TOOLS (TC 39)

[ISO 14955-2:2018](#), Machine tools - Environmental evaluation of machine tools - Part 2: Methods for measuring energy supplied to machine tools and machine tool components, \$209.00

MATERIALS, EQUIPMENT AND OFFSHORE STRUCTURES FOR PETROLEUM AND NATURAL GAS INDUSTRIES (TC 67)

[ISO 15138:2018](#), Petroleum and natural gas industries - Offshore production installations - Heating, ventilation and air-conditioning, \$232.00

MEDICAL DEVICES FOR INJECTIONS (TC 84)

[ISO 11070/Amd1:2018](#), Sterile single-use intravascular introducers, dilators and guidewires - Amendment 1, \$19.00

[ISO 20696:2018](#), Sterile urethral catheters for single use, \$162.00

[ISO 20697:2018](#), Sterile drainage catheters and accessory devices for single use, \$185.00

ONLINE REPUTATION (TC 290)

[ISO 20488:2018](#), Online consumer reviews - Principles and requirements for their collection, moderation and publication, \$138.00

PAINTS AND VARNISHES (TC 35)

[ISO 20266:2018](#), Paints and varnishes - Determination of image clarity (degree of sharpness of reflected or transmitted image), \$68.00

PLASTICS (TC 61)

[ISO 10927:2018](#), Plastics - Determination of the molecular mass and molecular mass distribution of polymer species by matrix-assisted laser desorption/ionization time-of-flight mass spectrometry (MALDI-TOF-MS), \$103.00

[ISO 20557-1:2018](#), Plastics - Poly(phenylene ether) (PPE) moulding and extrusion materials - Part 1: Designation system and basis for specifications, \$68.00

RUBBER AND RUBBER PRODUCTS (TC 45)

[ISO 3858:2018](#), Rubber compounding ingredients - Carbon black - Determination of light transmittance of toluene extract, \$68.00

[ISO 3949:2018](#), Plastics hoses and hose assemblies - Textile-reinforced types for hydraulic applications - Specification, \$68.00

[ISO 13226:2018](#), Rubber - Standard reference elastomers (SREs) for characterizing the effect of liquids on vulcanized rubbers, \$185.00

[ISO 28641:2018](#), Rubber compounding ingredients - Organic chemicals - General test methods, \$185.00

TRACTORS AND MACHINERY FOR AGRICULTURE AND FORESTRY (TC 23)

[ISO 11783-6:2018](#), Tractors and machinery for agriculture and forestry - Serial control and communications data network - Part 6: Virtual terminal, \$232.00

TRADITIONAL CHINESE MEDICINE (TC 249)

[ISO 20334:2018](#), Traditional Chinese medicine - Coding system of formulae, \$232.00

ISO Technical Reports**SAFETY OF TOYS (TC 181)**

[ISO/TR 8124-9:2018](#), Safety of toys - Part 9: Safety aspects related to mechanical and physical properties - Comparison of ISO 8124-1, EN 71-1, and ASTM F963, \$232.00

ISO/IEC JTC 1, Information Technology

[ISO/IEC/IEEE 26512:2018](#), Systems and software engineering - Requirements for acquirers and suppliers of information for users, \$185.00

IEC Standards**ALARM SYSTEMS (TC 79)**

[IEC 62676-5 Ed. 1.0 b:2018](#), Video surveillance systems for use in security applications - Part 5: Data specifications and image quality performance for camera devices, \$387.00

FIRE HAZARD TESTING (TC 89)

[IEC 60695-6-2 Ed. 2.0 b:2018](#), Fire hazard testing - Part 6-2: Smoke obscuration - Summary and relevance of test methods, \$235.00

INDUSTRIAL-PROCESS MEASUREMENT AND CONTROL (TC 65)

[IEC 61987-92 Ed. 1.0 b:2018](#), Industrial-process measurement and control - Data structures and elements in process equipment catalogues - Part 92: Lists of properties (LOP) of measuring equipment for electronic data exchange - Aspect LOPs, \$164.00

POWER SYSTEM CONTROL AND ASSOCIATED COMMUNICATIONS (TC 57)

[IEC 61850-6 Amd.1 Ed. 2.0 en:2018](#), Amendment 1 - Communication networks and systems for power utility automation - Part 6: Configuration description language for communication in power utility automation systems related to IEDs, \$410.00

[IEC 61850-6 Ed. 2.1 en:2018](#), Communication networks and systems for power utility automation - Part 6: Configuration description language for communication in power utility automation systems related to IEDs, \$1055.00

SEMICONDUCTOR DEVICES (TC 47)

[IEC 62435-4 Ed. 1.0 en:2018](#), Electronic components - Long-term storage of electronic semiconductor devices - Part 4: Storage, \$117.00

SUPERCONDUCTIVITY (TC 90)

[IEC 61788-23 Ed. 1.0 b:2018](#), Superconductivity - Part 23: Residual resistance ratio measurement - Residual resistance ratio of Nb superconductors, \$199.00

SURFACE MOUNTING TECHNOLOGY (TC 91)

[IEC 61189-2-630 Ed. 1.0 b:2018](#), Test methods for electrical materials, printed board and other interconnection structures and assemblies - Part 2-630: Test methods for materials for interconnection structures - Moisture absorption after pressure vessel conditioning, \$23.00

IEC Technical Reports**METHODS FOR THE ASSESSMENT OF ELECTRIC, MAGNETIC AND ELECTROMAGNETIC FIELDS ASSOCIATED WITH HUMAN EXPOSURE (TC 106)**

[IEC/TR 63167 Ed. 1.0 en:2018](#), Assessment of contact current related to human exposure to electric, magnetic and electromagnetic fields, \$164.00

Registration of Organization Names in the United States

The Procedures for Registration of Organization Names in the United States of America (document ISSB 989) require that alphanumeric organization names be subject to a 90-day Public Review period prior to registration. For further information, please contact the Registration Coordinator at (212) 642-4975.

The following is a list of alphanumeric organization names that have been submitted to ANSI for registration. Alphanumeric names appearing for the first time are printed in bold type. Names with confidential contact information, as requested by the organization, list only public review dates.

PUBLIC REVIEW

South Carolina Law Enforcement Division (SLED)

Public Review: April 27 to July 23, 2018

NOTE: Challenged alphanumeric names are underlined. The Procedures for Registration provide for a challenge process, which follows in brief. For complete details, see Section 6.4 of the Procedures.

A challenge is initiated when a letter from an interested entity is received by the Registration Coordinator. The letter shall identify the alphanumeric organization name being challenged and state the rationale supporting the challenge.

A challenge fee shall accompany the letter. After receipt of the challenge, the alphanumeric organization name shall be marked as challenged in the Public Review list. The Registration Coordinator shall take no further action to register the challenged name until the challenge is resolved among the disputing parties.

Proposed Foreign Government Regulations

Call for Comment

U.S. manufacturers, exporters, regulatory agencies and standards developing organizations may be interested in proposed foreign technical regulations notified by Member countries of the World Trade Organization (WTO). In accordance with the WTO Agreement on Technical Barriers to Trade (TBT Agreement), Members are required to notify proposed technical regulations that may significantly affect trade to the WTO Secretariat in Geneva, Switzerland. In turn, the Secretariat issues and makes available these notifications. The purpose of the notification requirement is to provide global trading partners with an opportunity to review and comment on the regulations before they become final.

The USA Inquiry Point for the WTO TBT Agreement is located at the National Institute of Standards and Technology (NIST) in the Standards Coordination Office (SCO). The Inquiry Point distributes the notified proposed foreign technical regulations (notifications) and makes the associated full-texts available to U.S. stakeholders via its online service, Notify U.S. Interested U.S. parties can register with Notify U.S. to receive e-mail alerts when notifications are added from countries and industry sectors of interest to them.

To register for Notify U.S., please visit <http://www.nist.gov/notifyus/>.

The USA WTO TBT Inquiry Point is the official channel for distributing U.S. comments to the network of WTO TBT Enquiry Points around the world. U.S. business contacts interested in commenting on the notifications are asked to review the comment guidance available on Notify U.S. at <https://tsapps.nist.gov/notifyus/data/guidance/guidance.cfm> prior to submitting comments.

For further information about the USA TBT Inquiry Point, please visit: <https://www.nist.gov/standardsgov/what-we-do/trade-regulatory-programs/usa-wto-tbt-inquiry-point>

Contact the USA TBT Inquiry Point at:(301) 975-2918; Fax: (301) 926-1559; E-mail: usatbtep@nist.gov or notifyus@nist.gov.

Information Concerning

American National Standards

Call for Members

INCITS Executive Board – ANSI Accredited SDO and US TAG to ISO/IEC JTC 1, Information Technology

The InterNational Committee for Information Technology Standards (INCITS), an ANSI accredited SDO, is the forum of choice for information technology developers, producers and users for the creation and maintenance of formal de jure IT standards. INCITS' mission is to promote the effective use of Information and Communication Technology through standardization in a way that balances the interests of all stakeholders and increases the global competitiveness of the member organizations.

The INCITS Executive Board serves as the consensus body with oversight of its 40+ Technical Committees. Additionally, the INCITS Executive Board has the international leadership role as the US Technical Advisory Group (TAG) to ISO/IEC JTC 1, Information Technology.

Membership in the INCITS Executive Board is open to all directly and materially affected parties in accordance with INCITS membership rules. To find out more about participating on the INCITS Executive Board, contact Jennifer Garner at jgarner@itic.org or visit <http://www.incits.org/participation/membership-info> for more information.

Membership in all interest categories is always welcome; however, the INCITS Executive Board seeks to broaden its membership base in the following categories:

- Service Providers
- Users
- Standards Development Organizations and Consortia
- Academic Institutions

Society of Cable Telecommunications

ANSI Accredited Standards Developer

SCTE, an ANSI-accredited SDO, is the primary organization for the creation and maintenance of standards for the cable telecommunications industry. SCTE's standards mission is to develop standards that meet the needs of cable system operators, content providers, network and customer premises equipment manufacturers, and all others who have an interest in the industry through a fair, balanced and transparent process.

SCTE is currently seeking to broaden the membership base of its consensus bodies and is interested in new members in all membership categories to participate in new work in fiber-optic networks, advanced advertising, 3D television, and other important topics. Of particular interest is membership from the content (program and advertising) provider and user communities.

Membership in the SCTE Standards Program is open to all directly a materially affected parties as defined in SCTE's membership rules and operating procedures. More information is available at www.scte.org or by e-mail from standards@scte.org.

ANSI Accreditation Program for Greenhouse Gas Validation/Verification Bodies

Reaccreditation

Ecocert SA

Comment Deadline: July 16, 2018

In accordance with ISO 14065:2013, Greenhouse gases – Requirements for greenhouse gas validation and verification bodies for use in accreditation or other forms of recognition

Ecocert SA
Xavier Hatchondo
BP 47, Lieu dit Lamothe
L'Isle Jourdain 32600, France
Phone +33 (0) 5 62 07 66 75
E-mail: xavier.hatchondo@ecocert.com

On June 11, 2018, ANSI's Greenhouse Gas Validation/Verification Body Accreditation Committee granted Ecocert SA reaccreditation for the following:

Activity and Scope:

Validation of assertions related to GHG emission reductions and removals at the project level

3 – Land Use and Forestry

Verification of assertions related to GHG emissions reductions and removals at the project level

3 – Land Use and Forestry

Please send your comments by July 16, 2018 to Ann Howard, Director, Environmental Accreditation Programs, American National Standards Institute; 1899 L Street, NW, 11th Floor, Washington, DC 20036; Fax: 202-293-9287 or e-mail: ahoward@ansi.org.

International Organization for Standardization (ISO)

ISO Proposal for a New Field of ISO Technical Activity

Sustainable Finance

Comment Deadline: July 13, 2018

BSI, the ISO member body for the United Kingdom, has submitted to ISO a new work item proposal for the development of an ISO standard on Sustainable Finance, with the following scope statement:

Standardization in the field of Sustainable Finance

The program of work will promote the integration of sustainability considerations and environmental, social and governance (ESG) practices into institutional investment decision-making and wider finance management. It will ultimately look to support the alignment of the global financial system with sustainable development goals.

Anyone wishing to review the proposal can request a copy by contacting ANSI's ISO Team (isot@ansi.org), with a submission of comments to Steve Cornish (scornish@ansi.org) by close of business on Friday, July 13].

Information Concerning

Meeting Notice and Call for Members for the New INCITS Technical Committee on Governance of Organizations (US TAG to ISO/TC 309)

Organizational Meeting – Tuesday, June 19, 2018. The organizational meeting of the new committee INCITS/Governance of Organizations will be held via WebEx on Tuesday, June 19, 2018 from 11:00 AM to 5:00 PM (Eastern time). The agenda, related documents and instructions for joining the WebEx meeting will be distributed to organizational representatives requesting membership on the new committee. RSVPs for the meeting should be submitted to Jennifer Garner (jgarner@itic.org) as soon as possible

The INCITS Executive Board established a new Technical Committee INCITS/Governance of Organizations and delegated the US TAG responsibilities for ISO/TC 309 to this new INCITS Technical Committee.

Scope of ISO/TC 309 – Standardization in the field of governance relating to aspects of direction, control and accountability of organizations.

The INCITS committee will operate under the ANSI-accredited procedures for the InterNational Committee for Information Technology Standards (INCITS); (see [INCITS Organization, Policies and Procedures](#)). Additional information can also be found at <http://www.INCITS.org> and <http://www.incits.org/participation/membership-info>.

The complete meeting notice and membership information can be found at https://standards.incits.org/apps/group_public/document.php?document_id=98060&wg_abbrev=governance.

Information Concerning

Meeting Notices

ASTM Continuous Maintenance Information (Committee Meeting Schedules)

Listed below are the Meeting Months of the ASTM Committees submitting their standards for ANSI approval.

Contacts:

Jennifer L. Rodgers

ASTM International
 Director, Technical Committee Operations
 Phone: 610.832.9694
 E-mail: jrodgers@astm.org
www.astm.org

Kate Chalfin

ASTM International
 Manager, Technical Committee Operations
 Phone: 610.832.9717
 E-mail: kchalfin@astm.org
www.astm.org

Corice Leonard

ASTM International
 AA, Technical Committee Operations
 Phone: 610.832.9744
 E-mail: cleonard@astm.org
www.astm.org

Committee	Committee Name	1st Meeting	2nd Meeting	3rd Meeting
D02.94;D02.9401;D02.0F;D02.0J	Petroleum Products and Lubricants	June	December	
D20.23	Reinforced Plastic Piping Systems and Chemical Equipment	April	November	
D20.24	Plastic Building Products	April	November	

E05	Fire Standards	June	December	
E06.25	Whole Buildings and Facilities	April	October	
E11	Quality and Statistics	April	October	
E12.13	Photo luminescent Safety Markings	January	June	
E20.11; E20.12; E20.13; E20:14	Temperature Measurement:	May	November	
E28	Mechanical Testing: only E8/E8M, E18 and E23	May	November	
E34.50	Health and Safety Standards for Metal Working Fluids	April	October	
E36	Conformity Assessment	June	December	
E44.09	Photovoltaic Electric Power Conversion:	May		
E60.01	Sustainability: Only New WK44075	April	October	
F08	Sports Equipment and Facilities	May	November	
F11	Vacuum Cleaners	May	November	
F13.10	Traction for Footwear	January	June	

F15	Consumer Products: only F400 and F963	September	October	
F17.10;F17.11;F17.20;F17.25;F17.26;F17.60;F17.61;F17.62	Plastic Piping Systems	April	November	
F25	Ships and Marine Technology	June	December	
F26	Food Service Equipment	April	October	

ASME B16.14-2013 20XX
(Revision of ASME B16.14-2010) 2013

Proposed Revision of:

Ferrous Pipe Plugs, Bushings, and Locknuts With Pipe Threads

Draft Date 06/2018

TENTATIVE
SUBJECT TO REVISION OR WITHDRAWAL
Specific Authorization Required for Reproduction or Quotation
ASME Codes and Standards

MANDATORY APPENDIX II REFERENCES

~~The following is a list of standards and specifications referenced in this Standard:~~

ANSI/ASME B1.20.1-~~1983 (R2001)~~, Pipe Threads, General Purpose (Inch)
 ASME B16.3-~~2006~~, Malleable Iron Threaded Fittings: Classes 150 and 300
 ASME B16.4-~~2011~~, Gray Iron Threaded Fittings: Classes 125 and 250
 ASME B18.2.1-~~2012~~, Square, Hex, Heavy Hex, and Askew Head Bolts and Hex, Heavy Hex, Hex Flange, Lobed Head, and Lag Screws (Inch Series)
 Publisher: The American Society of Mechanical Engineers (ASME), Two Park Avenue, New York, NY

10016-5990; Order Department: 22 Law Drive, P.O. Box 2900, Fairfield, NJ 07007-2900 (www.asme.org)

2014 ✓ **Standard**
 ASTM A126-04(~~2009~~), Specification for Gray Iron Castings for Valves, Flanges, and Pipe Fittings
 ASTM E29-08, Standard Practice for Using Significant Digits in Test Data to Determine Conformance With Specifications **13**

Publisher: American Society for Testing and Materials (ASTM International), 100 Barr Harbor Drive, P.O. Box C700, West Conshohocken, PA 19428-2959 (www.astm.org)

The following is a list of publications referenced in this Standard. Unless otherwise specified, the latest edition of ASME publications shall apply. Materials manufactured to other editions of the referenced ASTM standards shall be permitted to be used to manufacture fittings meeting the requirements of this Standard as long as the fitting manufacturer verifies the material meets the requirements of the referenced edition.

ASME B16.15-2013

20XX

(Revision of ASME B16.15-2011)

2013

Proposed Revision of:

Cast Copper Alloy Threaded Fittings

Classes 125 and 250

Draft Date 06/2018

TENTATIVE

SUBJECT TO REVISION OR WITHDRAWAL

Specific Authorization Required for Reproduction or Quotation

ASME Codes and Standards

8 RIBS

The addition of ribs or lugs is permitted on threaded pipe fittings. Where ribs are used, it is recommended that their thickness be the same as specified for the metal thickness of the pipe fitting.

(a) Right-hand couplings shall not have more than two ribs.

(b) Right- and left-hand couplings shall have four or more ribs unless the left-hand opening is clearly marked "L," in which case the use of ribs is optional with the manufacturer.

(c) Wrought couplings do not require opening markings.

9 SURFACE FINISH

Cast pipe fittings shall be furnished with a rough exterior surface, free of sand inclusions, fins, and gate protrusions.

10 FITTING DIMENSIONS

~~(a) Tables of center-to-end dimensions are given for both straight and reducing pipe fittings. Dimensions and tolerances shown as whole or multiples of 0.5 mm may differ slightly in absolute value from the corresponding dimensions in Mandatory Appendix I. Any dimension that is within tolerance by either SI or Customary measurement is considered to be in conformance with this Standard.~~

~~(b) The dimensions shown in Tables 5 through 9 (Tables I-5 through I-9) for fittings are for use only when making patterns for the specific reducing pipe fitting in question and do not apply when a larger size pattern is bushed to make the reducing pipe fitting wanted. Reducing pipe fitting patterns shall be designed to produce wall thicknesses and detail and dimensions as required for the sizes involved.~~

~~(c) The sketches of fittings accompanying Tables 2 through 12 (Tables I-2 through I-12) are representative and are included for the purpose of illustration.~~

11 TOLERANCES

11.1 Convention

For determining conformance with this Standard, the convention for fixing significant digits where limits (maximum and minimum values) are specified shall be as defined in ASTM E29. This requires that an observed or calculated value be rounded off to the nearest unit in the last right-hand digit used for expressing the limit. Decimal values and tolerances do not imply a particular method of measurement.

11.2 Metal Thickness

Dimensional variations are unavoidable in the casting process. Patterns shall be designed to produce castings of metal thicknesses given in the tables. Metal thickness at no point shall be less than 90% of the thicknesses given in the tables.

11.3 Dimensions

The tolerances shown in Table 13 (Table I-13) shall be permitted in center-to-end and center-to-center dimensions of fittings; tolerances for end-to-end dimensions shall be twice those given. The largest opening in reducing pipe fittings governs the tolerances to be applied to all openings.

12 PRESSURE TEST

Pressure testing is not required; however, the fittings shall be capable of withstanding, without leakage, an internal fluid pressure of two times the 38°C (100°F) pressure rating for the duration of 1 min.

10.1 General

10.1.1 Tables of center-to-end dimensions are given for both straight and reducing pipe fittings. Dimensions and tolerances shown as whole or multiples of 0.5 mm may differ slightly in absolute value from the corresponding dimensions in Mandatory Appendix I. Any dimension that is within tolerance by either SI or Customary measurement is considered to be in conformance with this Standard.

10.1.2 The sketches of fittings accompanying Tables 2 through 12 (Tables I-2 through I-12) are representative and are included for the purpose of illustration.

10.2 Reducing Fittings

10.2.1 The dimensions of reducing fittings shown in Tables 5, 6, 7, 8, and 10 (Tables I-5, I-6, I-7, I-8, and I-10) are for use only when making patterns for the specific reducing pipe fitting in question and do not apply when a larger size pattern is reduced (i.e., "bushed") to make the reduction or reductions in the fitting. Reducing pipe fitting patterns shall be designed to produce wall thicknesses and detail and dimensions as required for the sizes involved.

10.2.2 The transition in wall thickness from one end size to another shall be in a manner that minimizes the addition of stress caused by sudden changes in direction or wall thickness.

10.2.3 Proof of design shall be verified by a hydrostatic pressure test made at ambient temperature in which pressure is applied for a continuous period of no less than one (1) minute and at a constant minimum pressure of no less than four (4) times the pressure rating of the largest size of end connection in the reducing fitting. Testing is considered successful only when no evidence of cracking, fracturing, or leakage is exhibited after holding for at least the minimum time at or above the required pressure.

MANDATORY APPENDIX II REFERENCES

ASTM B140/B140M-12(2017),
Standard Specification for
Copper-Zinc-Lead (Leaded Red
Brass or Hardware Bronze) Rod,
Bar, and Shapes

The following is a list of publications referenced in this Standard. Unless otherwise specified, the latest edition of ASME publications shall apply. Materials manufactured to other editions of the referenced ASTM standards may be used to manufacture fittings meeting the requirements of this Standard as long as the fitting manufacturer verifies the material meets the requirements of the referenced edition.

ASME B1.20.1, Pipe Threads, General Purpose (Inch)
ASME B16.3, Malleable Iron Threaded Fittings, Classes 150 and 300
ASME B16.4, Gray Iron Threaded Fittings, Classes 125 and 250
ASME B18.2.1, Square, Hex, Heavy Hex, and Askew Head Bolts and Hex, Heavy Hex, Hex Flange, Lobed Head, and Lag Screws (Inch Series)
Publisher: The American Society of Mechanical Engineers (ASME), Two Park Avenue, New York, NY 10016-5990; Order Department: 22 Law Drive, P.O. Box 2900, Fairfield, NJ 07007-2900 (www.asme.org)

~~ASTM B16/B16M-10, Specification for Free Cutting Brass Rod, Bar, and Shapes for Use in Screw Machines~~
~~ASTM B62-09, Specification for Composition Bronze or Ounce Metal Castings~~

ASTM B16/B16M-10 (2015), Standard
Specification for Free Cutting Brass Rod,
Bar, and Shapes for Use in Screw Machines
ASTM B62-17, Standard Specification for
Composition Bronze or Ounce Metal Castings

~~ASTM B140/B140M-07, Specification for Copper-Zinc-Lead (Leaded Red Brass or Hardware Bronze) Rod, Bar, and Shapes~~

14

ASTM B584-09a, Standard Specification for Copper Alloy Sand Castings for General Applications

ASTM E29-08, Standard Practice for Using Significant Digits in Test Data to Determine Conformance With Specifications

13

Publisher: American Society for Testing and Materials (ASTM International), 100 Barr Harbor Drive, P.O. Box C700, West Conshohocken, PA 19428-2959 (www.astm.org)

2015

ISO 9000: 2005, Quality management systems — Fundamentals and vocabulary¹

2015

ISO 9001: 2008/Cor 1:2009, Quality management systems — Requirements¹

ISO 9004: 2009, Managing for the sustained success of an organization — A quality management approach¹

Publisher: International Organization for Standardization (ISO), Central Secretariat, 1, ch. de la Voie-Creuse, Case postale 56, CH-1211 Genève 20, Switzerland/Suisse (www.iso.org)

¹ May also be obtained from American National Standards Institute (ANSI), 25 West 43rd Street, New York, NY 10036.

ASME B16.22-~~2013~~ 20XX

(Revision of ASME B16.22-~~2012~~) 2013

Proposed Revision of:

Wrought Copper and Copper Alloy Solder-Joint Pressure Fittings

Draft Date 06/2018

TENTATIVE
SUBJECT TO REVISION OR WITHDRAWAL
Specific Authorization Required for Reproduction or Quotation
ASME Codes and Standards

Table 3 Inspection Tolerance

Standard Water Tube and Pipe Thread Sizes	Tolerance, mm
$\frac{1}{8}$, $\frac{1}{4}$, $\frac{3}{8}$ [Note (1)]	± 1.3
$\frac{1}{2}$, $\frac{5}{8}$, $\frac{3}{4}$	± 1.5
1, $1\frac{1}{4}$, $1\frac{1}{2}$, 2	± 2.0
$2\frac{1}{2}$, 3, $3\frac{1}{2}$	± 2.8
4 and 5	± 3.0
6 and 8	± 4.1

NOTE:

(1) $\frac{1}{8}$ size is $\frac{1}{4}$ O.D. seamless copper tube for refrigeration service, etc., as listed in ASTM B280.

9.3 Ovality of Fitting End (C or FTG)

Maximum ovality of the fitting solder-joint end shall not exceed 1% of the maximum diameters shown in Table 1 (Table II-1). The average of the maximum and minimum diameters shall be within the dimensions shown in the Table.

9.4 Inside Diameter of Fitting

The minimum cross-sectional area of the inside diameter through the fitting body shall not be less than the theoretical minimum area defined by diameter O in Table 1 (Table II-1). The out-of-roundness condition of the cross-sectional area shall not exceed the value shown in Table 1 (Table II-1).

For reducer or adapter fittings, the smallest end diameter shall apply, provided that this diameter does not restrict the other outlets.

9.5 Wall Thickness

The minimum wall thickness shall not be less than that shown in Table 1 (Table II-1).

10 THREADED ENDS

Fitting threads shall be right-hand, conforming to ASME B1.20.1. They shall be taper threads (NPT).

10.1 Countersink or Chamfer

All internal threads shall be countersunk a distance no less than one-half the pitch of the thread, at an angle of approximately 45 deg with the axis of the thread. All external threads shall be chamfered at an angle of 30 deg to 45 deg from the axis. Countersinking and chamfering shall be concentric with the threads.

The length of threads shall be measured to include the countersink or chamfer.

10.2 Threading Tolerances

Tapered pipe threads (NPT) shall be checked by use of plug or ring gages in either standard or limit types.

polygonal or bead
with or without ribs

10.3 Design of Threaded Ends

The wrenching section of internally threaded ends shall be polygonal, and the wrenching section of externally threaded ends shall be furnished with either polygon or flats, at the manufacturer's option.

,ribs,

11 ALIGNMENT

The maximum allowable deviation in the angular alignment of any end from the specified axis position shall be $\frac{1}{2}$ deg (1 deg total). See Fig. 3.

12 GAGING**12.1 Preferred Gaging Method of Solder-Joint Ends**

The preferred method of gaging the diameter tolerances for external and internal ends shall be by the use of

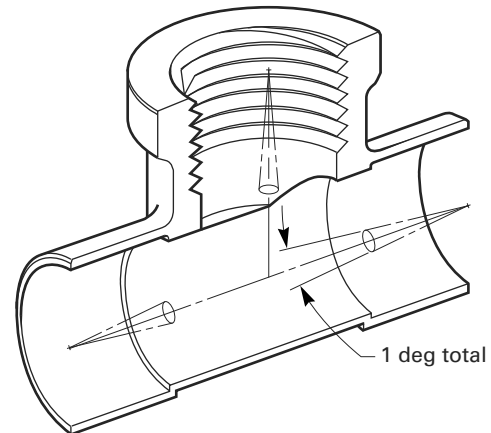
Fig. 3 Alignment

GENERAL NOTE: This figure is for illustration only.

When gaging internal taper threads, the plug gage shall be screwed hand-tight into the fitting. The reference point for gaging internal product threads depends on the chamfer diameter. When the internal chamfer diameter exceeds the major diameter of the internal thread, the reference point shall be the last thread scratch on the chamfer cone. Otherwise, when the internal chamfer diameter does not exceed the major diameter of the internal thread, the reference point shall be the end of the fitting. In gaging external taper threads, the ring gage shall be screwed hand-tight on the external thread. On the external thread, the ring gage shall be flush with the end of the thread.

Tolerance for an internal threaded end having an internal shoulder shall be from the gage reference point (notch) to one turn small. Tolerance for an internally threaded end without a shoulder, and for an externally threaded end, shall be from one turn small to one turn large.

ASTM E29-13, Standard Practice for Using Significant Digits in Test Data to Determine Conformance with Specification

MANDATORY APPENDIX III REFERENCES

The following is a list of standards and specifications referenced in this Standard, showing the year of approval.

~~2010~~ ASME Boiler and Pressure Vessel Code, Section II, Part B — Nonferrous Material Specifications
 ASME B1.20.1-~~1983 (R2006)~~, Pipe Threads, General Purpose (Inch)
 ASME B4.4M-~~1981 (R1994)~~, Inspection of Workpieces
 ASME B16.18-~~1984 (R2005)~~, Cast Copper Alloy Solder Joint Pressure Fittings
 ASME B31.1-~~2010~~, Power Piping
 ASME B31.9-~~2008~~, Building Services Piping
 Publisher: The American Society of Mechanical Engineers (ASME), Two Park Avenue, New York, NY 10016-5990; Order Department: 22 Law Drive, P.O. Box 2900, Fairfield, NJ 07007-2900 (www.asme.org)

~~ASTM B32-08, Specification for Solder Metal~~

~~ASTM B88-09, Specification for Seamless Copper Water Tube~~

~~ASTM B280-08, Specification for Seamless Copper Tube for Air Conditioning and Refrigeration Field Service~~

~~ASTM B819-00 (R2006), Specification for Seamless Copper Tube for Medical Gas Systems~~

~~ASTM B828-02 (R2010), Standard Practice for Making Capillary Joints by Soldering of Copper and Copper Alloy Tube and Fittings~~

~~ASTM E29-08, Practice for Using Significant Digits in Test Data to Determine Conformance with Specifications~~

Publisher: American Society for Testing and Materials (ASTM International), 100 Barr Harbor Drive, P.O. Box C700, West Conshohocken, PA 19428-2959 (www.astm.org) **2011**

AWS A5.8M-~~2004~~, Specification for Filler Metals for Brazing and Braze Welding¹

Publisher: American Welding Society (AWS), 8669 NW 36 Street, No. 130, Doral, FL 33166 (www.aws.org) **2015**

ISO 9000:2005, Quality management systems — Fundamentals and vocabulary¹ **2015**

ISO 9001:2008 ~~COR 1-2009~~, Quality management systems — Requirements¹

ISO 9004:2009, ~~Quality management systems Guidelines for performance improvements~~¹

Publisher: International Organization for Standardization (ISO) Central Secretariat, 1, ch. de la Voie-Creuse, Case postale 56, CH-1211, Genève 20, Switzerland/Suisse (www.iso.org) **2013**

MSS SP-25-~~2008~~, Standard Marking System for Valves, Fittings, Flanges and Unions

Publisher: Manufacturers Standardization Society of the Valve and Fittings Industry, Inc. (MSS), 127 Park Street, NE, Vienna, VA 22180 (www.mss-hq.org)

¹ May also be obtained from American National Standards Institute (ANSI), 25 West 43rd Street, New York, NY 10036.

Managing for the sustained success of an organization -- A quality management approach¹

The following is a list of publications referenced in this Standard. Unless otherwise specified, the latest edition of ASME publications shall apply. Materials manufactured to other editions of the referenced ASTM standards shall be permitted to be used to manufacture fittings meeting the requirements of this Standard as long as the fitting manufacturer verifies the material meets the requirements of the referenced edition.

ASTM B32-08(2014), Standard Specification for Solder Metal
ASTM B88-16, Standard Specification for Seamless Copper Water Tube
ASTM B280-16, Standard Specification for Seamless Copper Tube for Air Conditioning and Refrigeration Field Service
ASTM B819-00(2011), Standard Specification for Seamless Copper Tube for Medical Gas Systems
ASTM B828-16, Standard Practice for Making Capillary Joints by Soldering of Copper and Copper Alloy Tube and Fittings

ASME B16.26-2013
(Revision of ASME B16.26-2011)

20XX

2013

Proposed Revision of:

Cast Copper Alloy Fittings for Flared Copper Tubes

Draft Date 06/2018

TENTATIVE

SUBJECT TO REVISION OR WITHDRAWAL

Specific Authorization Required for Reproduction or Quotation
ASME Codes and Standards

CAST COPPER ALLOY FITTINGS FOR FLARED COPPER TUBES

1 SCOPE

This Standard establishes specifications for cast copper alloy fittings and nuts used with flared seamless copper tube conforming to ASTM B88 (water and general plumbing systems). Included are requirements for the following:

- (a) pressure rating
- (b) size
- (c) marking
- (d) material
- (e) dimensions
- (f) threading
- (g) hydrostatic testing

Fittings manufactured from cast copper alloys containing silicon shall be permanently marked with the designation Si.
Fittings manufactured from cast copper alloys containing bismuth shall be permanently marked with the designation B or Bi.

2 GENERAL

2.1 References

Codes, standards, and specifications containing provisions to the extent referenced herein constitute requirements of this Standard. These reference documents are listed in Mandatory Appendix II.

2.2 Convention

For determining conformance with this Standard, the convention for fixing significant digits where limits (maximum and minimum values) are specified shall be as defined in ASTM E29. This requires that an observed or calculated value be rounded off to the nearest unit in the last right-hand digit used for expressing the limit. Decimal values and tolerances do not imply a particular method of measurement.

2.3 Relevant Units

This Standard states values in both SI (Metric) and U.S. Customary units. These systems of units are to be regarded separately as standard. Within the text, the U.S. Customary units are shown in parentheses or in separate tables that appear in Mandatory Appendix I. The values stated in each system are not exact equivalents; therefore, it is required that each system of units be used independently of the other. Combining values from the two systems constitutes nonconformance with the Standard.

2.4 Quality Systems

Requirements relating to the product manufacturer's quality system programs are described in Nonmandatory Appendix B.

2.5 Service Conditions

Criteria for selection of materials suitable for particular fluid service are not within the scope of this Standard.

3 PRESSURE RATING

The fittings covered by this Standard are designed for a maximum cold-water service pressure of 1 200 kPa (175 psig).

4 SIZE

The sizes of the fittings shown in Table 1 (Table I-1) correspond to standard water tube size as defined in ASTM B88.

5 MARKING

Each fitting shall be marked with the manufacturer's name or trademark and other applicable markings as required by MSS SP-25. Marking of fittings less than nominal size $\frac{1}{2}$ is optional.

6 MATERIAL

(13)

(a) Castings intended for use in applications up to 400°F (204°C) shall be of a copper alloy produced to meet

(1) the requirement of ASTM B62 Alloy C83600 or

(2) the chemical and tensile requirements of ASTM B584 Alloy C83800 or C84400 and in all other respects comply with the requirements of ASTM B62

(b) Castings intended for use in potable water applications, up to 200°F (93°C), shall be low lead (0.25% or less) and shall be

(1) of a copper alloy produced to meet the requirements of ASTM B584 Alloy C87850 or C89833 or

(2) of other cast copper alloys, provided the fittings produced meet mechanical and corrosion-resistant properties needed for potable water application

7 DIMENSIONS

7.1 Fitting and Nut

The dimensions and tolerances of fittings and nuts shall be as shown in Table 1 (Table I-1). Design of the sealing surfaces of the fitting and nut shall be at the discretion of the manufacturer.

MANDATORY APPENDIX II REFERENCES

shall be permitted
to

The following is a list of publications referenced in this Standard. Unless otherwise specified, the latest edition of ASME publications shall apply. Materials manufactured to other editions of the referenced ASTM standards ~~may~~ be used to manufacture fittings meeting the requirements of this Standard as long as the fitting manufacturer verifies that material meets the requirements of the referenced edition.

ASME B1.1, Unified Inch Screw Threads (UN and UNR Thread Form)

ANSI/ASME B1.20.1, Pipe Threads, General Purpose (Inch)

Publisher: The American Society of Mechanical Engineers (ASME), Two Park Avenue, New York, NY 10016-5990; Order Department: 22 Law Drive, P.O. Box 2900, Fairfield, NJ 07007-2900 (www.asme.org)

ASTM B62-09, Standard Specification for Composition Bronze or Ounce Metal Castings

ASTM B88-09, Standard Specification for Seamless Copper Water Tube

ASTM B584-09a, Standard Specification for Copper Alloy Sand Castings for General Applications

ASTM E29-08, Standard Practice for Using Significant Digits in Test Data to Determine Conformance With Specifications

Publisher: American Society for Testing and Materials (ASTM International), 100 Barr Harbor Drive, P.O. Box C700, West Conshohocken, PA 19428-2959 (www.astm.org)

ISO 9000: 2005, Quality management systems — Fundamentals and vocabulary¹

ISO 9001: 2008/Cor 1:2009, Quality management systems — Requirements¹

ISO 9004: 2009, Managing for the sustained success of an organization — A quality management approach¹

Publisher: International Organization for Standardization (ISO), Central Secretariat, 1, ch. de la Voie-Creuse, Case postale 56, CH-1211 Genève 20, Switzerland/Suisse (www.iso.org)

MSS SP-25-2008, Standard Marking Systems for Valves, Fittings, Flanges and Unions

Publisher: Manufacturers Standardization Society of the Valve and Fittings Industry, Inc. (MSS), 127 Park Street NE, Vienna, VA 22180 (www.mss-hq.org)

¹ May also be obtained from American National Standards Institute (ANSI), 25 West 43rd Street, New York, NY 10036.

13

17

16

14

2015

2015

2013

Not for publication. This document is part of the NSF International standard development process. This draft text is for circulation for review and/or approval by a NSF Standards Committee and has not been published or otherwise officially adopted. All rights reserved. This document may be reproduced for informational purposes only.

[Note – the changes are illustrated below using ~~strikeout~~ for proposed removal of existing text and grey highlights to indicate the proposed new text. ONLY the highlighted text and ~~strikeout~~ text is within the scope of this ballot. Rationale Statements are in RED and only used to add clarity; these statements will NOT be in the finished publication]

NSF/ANSI Standard 49 for Biosafety Cabinetry — Design, Construction, Performance, and Field Certification

.
. .
.

5 Design and construction

.
. .
.

5.26.2 Electrical wiring, switches, etc.

Replaceable electrical components shall not be located in contaminated air plenums, except for fan motors, sealed nonporous or jacketed wiring, and necessary airflow sensors. All wiring penetrations of contaminated spaces shall be sealed in accordance with 6.2. Circuit overload protection shall be provided for all receptacles. Switches shall be mounted outside the work area. Cabinet wiring diagram(s), such as assembly or ladder schematic, shall be accessible by downloadable barcode, permanent label or sealed plastic pouch attached to a cabinet panel or surface located outside of air plenums systems. A statement providing starting current, maximum current/full load ampere (FLA) rating ~~running power~~, and circuit requirements shall be provided with the installation instructions.

Rationale: Direct Current motors, ECM motors and 3-phase motors will draw more power as the BSC filters load, or if inflow and downflow are increased. This proposed language allows for some understood tolerance in this phrase in section 5.26.2.

Tracking number 53i109r1
© 2018 NSF International

Revision to NSF/ANSI 53 – 2017
Draft 1, Issue 109 (May 2018)

Not for publication. This document is part of the NSF International standard development process. This draft text is for circulation for review and/or approval by a NSF Standards Committee and has not been published or otherwise officially adopted. All rights reserved. This document may be reproduced for informational purposes only.

[Note – the changes are seen below using strikethrough for removal of old text and gray highlights to show the suggested text. ONLY the highlighted text is within the scope of this ballot.]

NSF International Standard / American National Standard –

Drinking water treatment units – Health effects

7.3.1 Asbestos reduction testing

.
.

7.3.1.6 Methods

.
.

7.3.1.6.4 Squeeze bottle drinking water treatment units

Products meeting the definition for squeeze drawn drinking water treatment unit shall be evaluated using the method specified in Annex G.

Two units shall be conditioned in accordance with the manufacturer's instructions using the appropriate general test water specified in Section 7.3.1.4.1 without the test contaminant present.

7.3.1.6.5 Batch treatment systems

7.3.1.6.5.1 Systems with a manufacturer's recommended use pattern

Two systems shall be tested using the appropriate influent challenge water using the manufacturer's use pattern. The use pattern shall include information about the rest period between the fillings. The volume per batch shall be the filling volume of the influent reservoir. The systems shall be operated up to 16 h per 24 h period, followed by an 8 h rest period.

7.3.1.6.5.2 Systems without a manufacturer's recommended use pattern

Two systems shall be conditioned by completely filling the raw water reservoir with the general test water specified in 7.3.1.4.1 without the asbestos fibers. The challenge water shall be allowed to filter until it reaches its natural level in the raw and treated water reservoirs. A filling cycle shall be established based on the time required for half the water to filter through the initial cycle. The filling schedules shall be maintained 16 h per 24 h period followed by an 8 h rest period. The systems shall be filled completely each cycle with a measured volume. Treated water shall be discarded as necessary.

NOTE — If the sample period occurs near the end of the 16 h of operation and the sample collection would extend beyond the 16 h period, the collection of the sample may be delayed until the start of the next 16 h period.

7.3.1.6.5.3 Asbestos challenge procedure

The asbestos challenge procedure shall be performed as follows:

Tracking number 53i109r1
© 2018 NSF International

Revision to NSF/ANSI 53 – 2017
Draft 1, Issue 109 (May 2018)

Not for publication. This document is part of the NSF International standard development process. This draft text is for circulation for review and/or approval by a NSF Standards Committee and has not been published or otherwise officially adopted. All rights reserved. This document may be reproduced for informational purposes only.

- a) The asbestos suspension specified in 7.3.1.4.3 shall be added to the water just prior to the sample point. The asbestos suspension specified feed shall be 10 bed volumes, or 1 filling volume of the influent reservoir, whichever is greater.
- b) The test dust loading water, specified in 7.3.1.4.2, shall be used until the time required to complete one cycle has increased by 133% of the original cycle time.
- c) The asbestos challenge test water, specified in 7.3.1.4.3, shall be used for 10 bed volumes, or 1 filling volume of the influent reservoir, whichever is greater.
- d) The test dust loading water shall be used until the time required for one filling cycle has increased by 200% from the original cycle time.
- e) The asbestos challenge test water, specified in 7.3.1.4.3, shall be used for 10 bed volumes, or 1 filling volume of the influent reservoir, whichever is greater.
- f) The test dust loading water shall then be used until the time required for 1 filling cycle has increased by 400% from the original cycle time.
- g) The asbestos challenge test water, specified in 7.3.1.4.3, shall be used for 10 bed volumes, or 1 filling volume of the influent reservoir, whichever is greater.

7.3.1.7 Sampling

Influent and effluent samples shall be collected at the beginning of the "on" cycle at the start of the test (beginning with the 4th cycle) and after each "off" cycle when the original flow from the system has decreased 25%, 50%, and 75%. The volume of the system downstream of the mechanical filtration element shall be determined. Samples shall be collected after the introduction of the challenge test water when the effluent from the previous cycle has been flushed from the system downstream of the mechanical filtration element and the sample apparatus. Sample size shall be 1 L.

7.3.1.7.1 Batch treatment systems

Influent and effluent samples shall be collected:

- At the beginning of the "on" portion of the second cycle, or passage of 10 bed volumes; and
- At the beginning of the "on" portion of the second cycle of challenge test water introduced when the original filling time of the system has increased by 133%, 200%, and 400%.

7.3.2 Cyst reduction

The system shall be tested using one of the following options:

- live *Cryptosporidium parvum* oocysts (see Section 7.3.2.1); or
- polystyrene microspheres (see Section 7.3.2.2).

Tracking number 53i109r1
© 2018 NSF International

Revision to NSF/ANSI 53 – 2017
Draft 1, Issue 109 (May 2018)

Not for publication. This document is part of the NSF International standard development process. This draft text is for circulation for review and/or approval by a NSF Standards Committee and has not been published or otherwise officially adopted. All rights reserved. This document may be reproduced for informational purposes only.

Rationale: Added protocol for asbestos reduction for batch treatment systems per 2018 DWTU JC meeting discussion (May 9, 2018).

Formatted: Not Highlight

Formatted: Not Highlight

Formatted: Font: Bold, Italic, Not Highlight

Not for publication. This document is part of the NSF International standard development process. This draft text is for circulation for review and/or approval by a NSF Standards Committee and has not been published or otherwise officially adopted. All rights reserved. This document may be reproduced for informational purposes only.

NSF/ANSI Standard For Wastewater Technology –

Onsite residential and commercial water reuse treatment systems

-
-
-

3.15 30-day (30-d) average: The average of daily measurements over a 30-day period, calculated as the sum of all daily measurements taken during a 30-day period divided by the number of daily measurements taken during that 30-day period. When a sample result is less than the detection limit, the detection limit shall be used as the value for the purpose of calculating the 30-day average. ~~When all of the sample results in a 30-day period are less than the detection limit, the 30-day average shall be reported as less than the detection limit.~~

3.16 30-day (30-d) geometric mean (geo mean): A type of average, calculated as the nth root of the product of n values (daily measurements) taken over a 30-day period. For example, If 10 measurements were taken over a 30-day period, the geometric mean of those measurements would be the 10th root of the product of those 10 measurements $\sqrt[10]{X_1 * X_2 * ... * X_{10}}$. ~~When a sample result is less than the detection limit, the detection limit shall be used as the value for the purpose of calculating the 30-day geometric mean. When all of the sample results in a 30-day period are less than the detection limit, the 30-day geometric mean shall be reported as less than the detection limit.~~

Rationale: Definitions cannot contain requirements (shall). These have been moved to Section 8, performance testing and evaluation

-
-
-

8 Performance testing and evaluation

The analytical methods listed in Table A.1 shall be used for testing. Alternate methods ~~may also be used~~ are permissible, provided equivalency is demonstrated by technical review and the review is documented. An equivalent method involves the same measurement technique. Equivalent methods are known to be capable of generating reliable results to equivalent quality requirements. All sample collection methods shall be in accordance with *Standard Methods* unless otherwise specified.

Rationale: avoid use of the word "may"

-
-
-

8.6 Criteria (applicable to all reuse systems evaluated in accordance with 8.1, 8.2, and 8.3)

8.6.1 General

8.6.1.1 If conditions during the testing and evaluation period result in system upset, improper sampling, improper dosing, or influent characteristics outside of the specified ranges, an assessment shall be conducted to determine the extent to which these conditions adversely affected the performance of the

Not for publication. This document is part of the NSF International standard development process. This draft text is for circulation for review and/or approval by a NSF Standards Committee and has not been published or otherwise officially adopted. All rights reserved. This document may be reproduced for informational purposes only.

system. Based on this assessment, it is acceptable to exclude specific data points ~~may be excluded~~ from the averages of effluent measurements. Rationale for all data exclusions shall be documented in the final report.

Rationale: avoid use of the word "may"

8.6.1.2 In the event that a catastrophic site problem not described in this Standard including, but not limited to, influent characteristics (including influent total coliform or *E.coli* results exceeding the single sample maximum values during testing under 8.1), malfunctions of test apparatus, and acts of nature, jeopardizes the validity of the performance testing and evaluation, manufacturers shall be given the choice to:

- perform maintenance on the system, reinitiate system start-up procedures, and restart the performance testing and evaluation; or
- with no routine maintenance performed, have the system brought back to pre-existing conditions and resume testing within 3 wk (21 d) after the site problem has been identified and corrected. Data collected during the system recovery period shall be excluded from averages of effluent measurements.

NOTE — Pre-existing conditions shall be defined as the point when the results of 3 consecutive data days are within 15% of the previous 30-d average(s).

8.6.1.3 During the design loading sequence, a minimum of 2/3 of the total scheduled data days shall be necessary for the test to be considered valid.

8.6.1.4 During the stress loading sequence (8.1.2.2.2 and 8.2.2.2.2), a minimum of 2/3 of the total scheduled data days and from at least one of the scheduled data days during any single stress recovery shall be necessary for the test to be considered valid.

8.6.1.5 A 30-d average or 30-d geo mean average discharge value shall consist of a minimum of 50% of the regularly scheduled sampling days per month. If a calendar month contains less than the required number of data days, it is permissible to transfer sufficient data days from the preceding calendar month to constitute a 30-d average or 30-d geo mean discharge value. If there are not sufficient data days available in the preceding calendar month, it is permissible for the transfer of data days to take place from the following calendar month to constitute a 30-d average or 30-d geo mean discharge value. No data day shall be included in more than one 30-d average or 30-d geo mean discharge value.

8.6.1.6 When a sample result is less than the detection limit, the detection limit shall be used as the value for the purpose of calculating the 30-d average or 30-d geo mean. When all of the sample results in a 30 day period are less than the detection limit, the 30-d average or 30-d geo mean shall be reported as less than the detection limit.

BSR/UL 73, Standard for Motor-Operated Appliances

PROPOSAL

6.3.7 To reduce the risk of injury due to battery ingestion, an appliance covered by this Standard, or any accessory of the appliance, intended for use with one or more single cell batteries, shall comply with 6.3.8 if the batteries are:

- a) Single cell batteries of lithium technologies;
- a b) Diameter of 1.25 inch (32 mm) or less; and
- b c) Height that is less than its diameter.

UL copyrighted material. Not authorized for further reproduction without prior permission from UL.

BSR/UL 588, Standard for Safety for Seasonal and Holiday Decorative Products

1. Parallel-Connected Lighting Strings Employing 18 AWG Conductors

PROPOSAL

Table 13.1

Maximum conductor current and overcurrent protection

Wire size, AWG (mm ²)	Maximum conductor current/ <u>wattage</u> amperes/ <u>watts</u>	Overcurrent protection amperes
12 (3.31)	12/ <u>1440</u>	N/A
14 (2.08)	12/ <u>1440</u>	N/A
16 (1.31)	10/ <u>1200</u>	10 ^b
18 (0.82)	8 ^a / <u>960</u>	8 ^a
20 (0.52)	3.6/ <u>432</u>	5
22 (0.32)	1.8/ <u>216</u>	3

^a When an 8 A fuse is employed, the maximum current shall not exceed 8 A. When a 5 A fuse is employed, the maximum current shall not exceed 3.6 A.

^b Overcurrent is required only when more than 3 load fittings are employed. A maximum of 6 load fittings are permitted when overcurrent protection is provided.

29.1 A parallel-connected string shall employ only intermediate- or candelabra-screw lampholders, and shall have at least 7 lampholders, and but the total wattage of the lighting string shall not exceed 216 Watts (1.8 A) when a cord connector is provided or 432 Watts (3.6 A) when no cord connector is provided the conductor current as indicated in Table 13.1.

125.4.3 A lighting string or a decorative outfit consisting of a lighting string with decorative covers which that employs a polarized load fitting shall be marked within 3 inches (76.2 mm) of the face of the load fitting with the word "CAUTION" and the following: "This lighting string is rated ___ Watts (___ Amps), do not overload. Connect other lighting strings or decorative outfits end-to-end up to a maximum of ~~432~~ ___ Watts (~~3.6~~ ___ Amps) total." The first blank shall be filled in with the rated wattage of the product. The second blank shall be filled in with the rated amperage of the product. The third blank shall be filled in with the conductor wattage based on 120 V times the maximum conductor current described in Table 13.1. The fourth blank shall be filled in with the maximum total current in Amps described in Table 13.1. Additional instructions shall be provided with the user servicing instructions to further explain the wattage,

where to find the wattage rating on the product and where to find the current rating on products that do not contain a wattage rating.

125.5.1 A product with an input current in excess of ~~1.75~~ 1.8 A or ~~which employs more than 30 parallel-connected lampholders,~~ shall be marked with the following: "CAUTION - Do not connect to another lighting string, decorative outfit, or seasonal product."

2. Glass LED Lamps Used in Parallel-connected or Series-Connected Lighting Strings

PROPOSAL

125.3.11 Products employing glass LED lamps complying with SA11A.1 shall be marked "CAUTION - RISK OF ELECTRIC SHOCK. Do not use if outer lamp envelope is damaged or broken."

SA11A Glass LED Lamps

SA11A.1 When subjected to a single drop described in 59.1, lamp breakage is considered acceptable provided that for all three lamps, there is no accessibility of live parts or a minimum of 75% of each sample's outer envelope surface area above its base contacts breaks away or becomes permanently separated.

SA11A.2 Products employing lamps complying with this Section shall be marked in accordance with 125.3.11.

UL copyrighted material. Not authorized for reproduction without permission from UL.

BSR/UL 817, Standard for Safety for Cord Sets and Power-Supply Cords

1. Addition of Requirements for Testing of Electronic Circuitry, New 9.12.1 - 9.12.3 and New Section 19A

PROPOSAL

9.12.1 A polymeric material used as an enclosure or in contact with electrical components shall have a suitable relative thermal index rating in accordance with the Standard for Polymeric Materials - Short Term Property Evaluations, UL 746A, or the Standard for Polymeric Materials - Long Term Property Evaluations, UL 746B.

9.12.2 A printed wiring board shall comply with the Standard for Printed-Wiring Boards, UL 796, and have a minimum flammability rating of HB as determined by the applicable tests in the Standard for Tests for Flammability of Plastic Materials for Parts in Devices and Appliances, UL 94.

9.12.3 The temperature measured on a printed wiring board shall not exceed its maximum operating temperature when tested in accordance with the Temperature Test, 12.2, when corrected to 25°C (77°F) ambient temperature.

19A Tests for Electrical Components

19A.1 The breakdown of an electrical component as simulated by the test described in 19A.2 - 19A.9 shall not result in the risk of injury to persons, or the risk of fire or electric shock as determined by the existence of any of the following conditions:

- a) Glowing, charring, or flaming of the cheesecloth or tissue paper specified in 19A.4;
- b) The opening of the 3 A fuse connected to ground specified in 19A.5;
- c) Emission of flame, sparks, or molten metal from the enclosure;
- d) Development of an opening in the overall enclosure that exposes live parts and increases the risk of electric shock (see 6.3); or
- e) Loss of structural integrity to such a degree that the equipment collapses or experiences displacement of parts that may:
 - 1) Lead to short-circuiting or grounding of live parts.
 - 2) Affect the function of any safety controls such as thermostats, overload protective devices, waterseals, or strain relief.

A component located in the supplementary circuit in accordance with 9.8 or an optical isolator that complies with the requirements in the Standard for Optical Isolators, UL 1577 need not be subjected to this test.

19A.2 The malfunction of a component such as a diode, a transistor, a thyristor, an electrolytic capacitor, an integrated circuit, an optical isolator, or other electronic component which has not been determined to be reliable by a reliability investigation and which could result in a risk of fire or electric shock, are to be simulated. In order to simulate the malfunction of a component, the circuit between any two terminals of the component is to be opened and/or shorted. Only one of the two simulated fault conditions is to be imposed at one time. For a multi-terminal device, only two terminals are to be short-circuited at a time. Simulated circuits may be used, but if the tests performed on simulated circuits indicate likely damage to other parts of the product to the extent that the safety of the product may be affected, the test is to be repeated on the product.

19A.3 Each simulated fault condition is to be conducted on a separate unit unless it is agreeable to all those concerned that more than one test be conducted on the same unit.

19A.4 The unit is to be placed on a softwood surface covered with white tissue paper. A single layer of cheesecloth is to be draped loosely over the entire enclosure.

19A.5 Exposed dead-metal parts of the unit are to be connected to ground through a 3 A non-time-delay fuse.

19A.6 The unit is to be connected to a 60 Hz, 120 V supply source. The supply circuit is to have a minimum 20 A branch circuit overcurrent protection.

19A.7 The test is to be conducted for 7 hours or until at least one of the following results are observed:

- a) A risk of fire or electric shock develops,
- b) The branch-circuit overcurrent protection opens,
- c) The equipment protective device opens,
- d) Any other circuit component opens, or
- e) A minimum of one hour elapses, circuit conditions stabilize, and there is no further evidence of overheating of parts.

19A.8 With reference to of 19A.7(e), the overheating of parts may be detected by an indicator such as an odor, smoke, discoloration, cracking of materials, charring, flaming, glowing, arcing, changes in circuit current through the applied fault, or any similar phenomenon.

19A.9 If a fault condition is terminated by opening of a circuit component as specified in 19A.7(d), the test is to be conducted two more times using new components for each test.

BSR/UL 1647, Standard for Safety for Motor-Operated Massage and Exercise Machines

1. Construction requirement revision or clarification for Wood or Wood Composite Enclosure Materials

7.1.5.1 With respect to resistance to combustion, wood or wood composite materials used to form outer enclosures shall be separated from ignition sources. In addition, the construction shall comply with the following:

- a) The enclosure shall comply with the Impact Test of 66.2 without exposure of live parts, including insulated wiring, or moving parts capable of causing injury; and
- b) Temperatures on the enclosure material during normal operation shall not exceeding the limit specified in Table 49.1 for wood or other combustible material

7.1.5.2 Ignitions sources within line-voltage circuits of the appliance are considered to be:

- a) uninsulated electrical connections, such as splicing wire connectors, quick-connect terminals, terminal connectors and other forms of wire connectors,
- b) printed circuit board traces,
- c) open coils and windings,
- d) open contacts, and
- e) wiring not employing VW-1 insulation.

Exception No. 1: Type S, SE, SO, SOO, ST, STO, STOO, SJ, SJE, SJO, SJOO, SJT, SJTO, AND SJTOO power cords are not considered to be ignition sources.

Exception No. 2: Impedance protected motors employing open-coil or exposed winding constructions are not considered to be ignition sources if they comply with 7.1.7(a)(2) without emission of flames or molten metal from the motor housing.

Exception No. 3: Thermally protected motors having openings in their enclosures are not considered to be ignition sources if they comply with the requirements in 7.1.7(a)(3) or 7.1.7(a)(4).

Exception No. 4: Transformers complying with the Standard for Low Voltage Transformers: General Requirements, UL 5085-1, and the Standard for Low Voltage Transformers: General Purpose Transformers, UL 5085-2, are not considered to be ignition sources.

7.1.5.3 Separation of ignition sources from wood or wood composite materials shall consist of barriers and spacing as illustrated in Figure 7.2 as follows:

a) A part located vertically below the ignition source and within Space A of Figure 7.2 shall be isolated by means of a barrier located and sized so that the barrier covers 5° beyond each side of the ignition source as illustrated in Fig 7.2.

b) A part located vertically above the ignition source and within Space B of Figure 7.2 shall be isolated by means of a barrier located and sized so that the barrier covers 30° beyond each side of the ignition source as illustrated in Figure 7.2 and so that the minimum distance between the nonmetallic material and ignition source is no less than 4 inches (102 mm).

c) A part located horizontally from the ignition source shall be isolated by means of a barrier located and sized so that the minimum straight line distance between the nonmetallic material and the ignition source is no less than 4 inches (102 mm).

Exception: When the only ignition source is wiring not employing VW-1 insulation the minimum distance between the nonmetallic material and the ignition source may be 2 inches (51 mm).

UL copyrighted material. Not authorized for further reproduction without permission from UL.

Figure 7.2

Separation of ignition sources from wood or wood composite materials

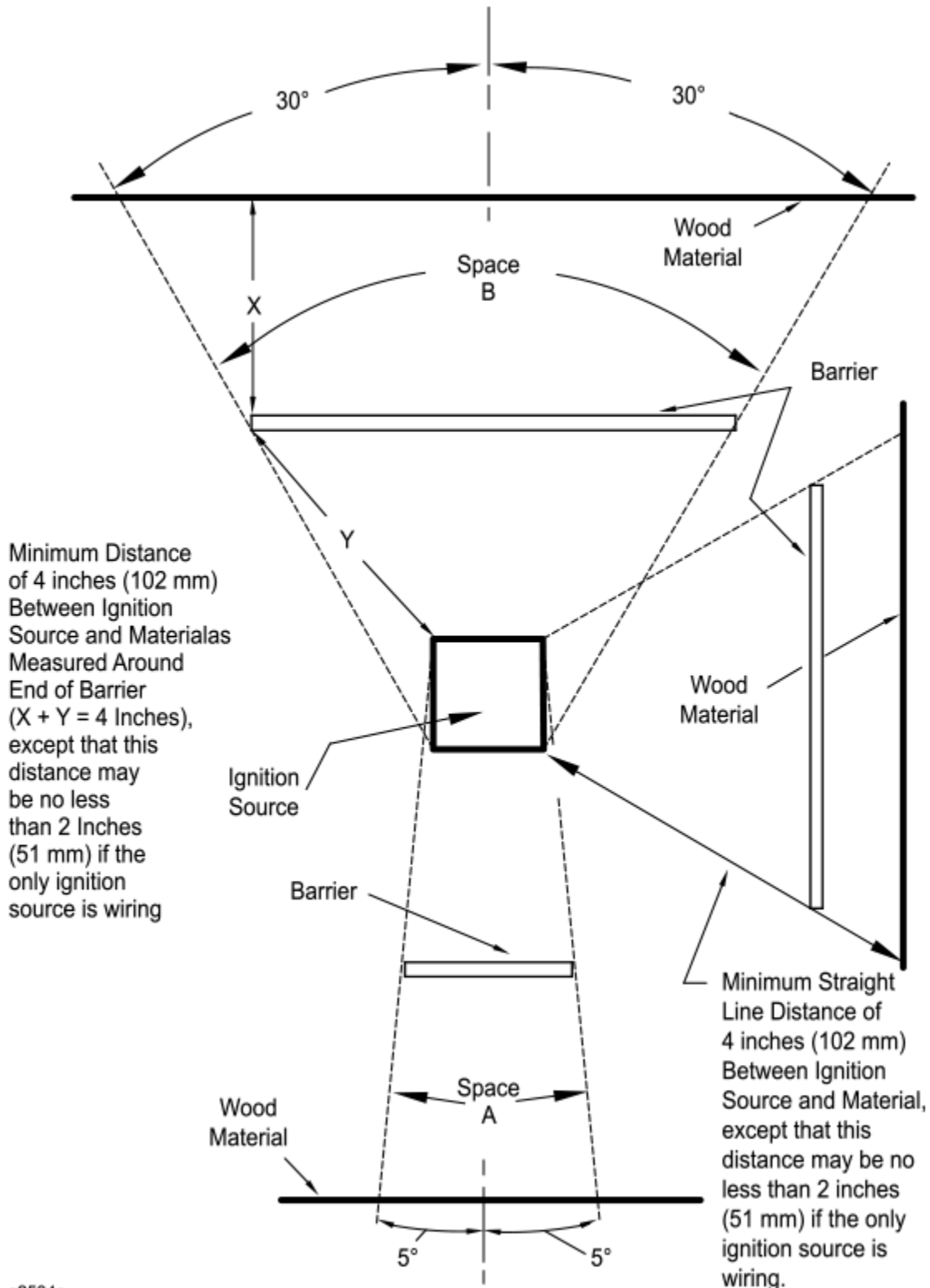

UL

rom UL

7.1.5.4 The barrier specified in 7.1.5.3 shall be of metal or a nonmetallic material having a flammability class as specified in 7.2.1.

UL copyrighted material. Not authorized for further reproduction without prior permission from UL.

BSR/UL 2353, Standard for Safety for Single- and Multi-Layer Insulated Winding Wire**1. Proposal to Revise insulation thickness**

6.11 For single and multi-layer wires, one thickness measurement is to be made in each of the 4 quadrants of the circular sample, for each layer as shown in Figure 6.1. The measurements shall be made at the ~~thickest~~ thinnest point for each layer in a given quadrant. For example, a reinforced insulation wire consisting of 3 layers should have three measurements made in each quadrant, one for the inner most layer, one for the middle layer and one for the outer layer. The diameter of the conductor and the overall conductor diameter (conductor and all layers of insulation) shall also be measured in the same fashion as the individual layers. The same logic applies for basic and supplementary insulation. The thickness of an enameled, bond coat or other non-insulating layer is not required to be measured.

6.14 The ~~thickest~~ measurement for each size wire is used as the minimum thickness for that particular layer. For example, when 18 AWG and 32 AWG is selected to represent the size range and 0.038 mm (0.0015 in) is the thickness measurement for inner most layer in any quadrant of the 18 AWG wire and 0.046 mm (0.0018 in) is the ~~thickest~~ measurement for the inner most layer in any quadrant of the 32 AWG wire, 0.046 mm (0.0018 in) is reported as the minimum thickness for the inner most layer for the entire size range.

6.14 The minimum wall thickness for the insulation layers should be determined as shown in Table 6.1:

Table 6.1*Minimum wall thickness for insulation layers*

Layers	18 AWG: Quadrant (mm)				32 AWG: Quadrant (mm)			
	1	2	3	4	1	2	3	4
Inner ^a	<u>0.025</u>	<u>0.030</u>	<u>0.027</u>	<u>0.029</u>	<u>0.029</u>	<u>0.031</u>	<u>0.033</u>	<u>0.028</u>
Middle ^b	<u>0.040</u>	<u>0.039</u>	<u>0.044</u>	<u>0.037</u>	<u>0.045</u>	<u>0.046</u>	<u>0.042</u>	<u>0.038</u>
Outer ^c	<u>0.019</u>	<u>0.020</u>	<u>0.018</u>	<u>0.020</u>	<u>0.017</u>	<u>0.019</u>	<u>0.020</u>	<u>0.019</u>
^a For the inner layer, 0.028 mm would be the minimum wall thickness since each wire size measured at least 0.028 mm in at least one quadrant.								
^b For the middle layer, 0.038 mm would be the minimum wall thickness since each wire size measured at least 0.038 mm in at least one quadrant.								
^c For the outer layer, 0.018 mm would be the minimum wall thickness since each wire size measured at least 0.018 mm in at least one quadrant.								